

**COVERNIT**

Montážní návod

# PERGOLA VILSTE



**2x**



**240 min**



**COVERNIT s.r.o.**



INFO@COVERNIT.cz



www.COVERNIT.cz

## Manual del usuario

Please check local building codes regarding footings, location and other requirements before beginning construction. Study and understand this owner's manual of important information and helpful tips for easier and more enjoyable assembly.

## Assembly instructions:

Reviewing all instructions and the appropriate information before you begin, make sure following the step sequence carefully for successful results.

## Parts and Parts List:

Before you start, separate and identify all the parts and hardware to be sure that you have all the necessary parts for your building (refer to the Parts List Page).

If you find that a part is missing, please notify the seller within one week after receiving the product. Do not attempt to assemble the building if parts are missing because any building left partially assembled may be seriously damaged by light winds.

**( Please tear off the safety protection layer before the assembly, keep the part number label if needed )**









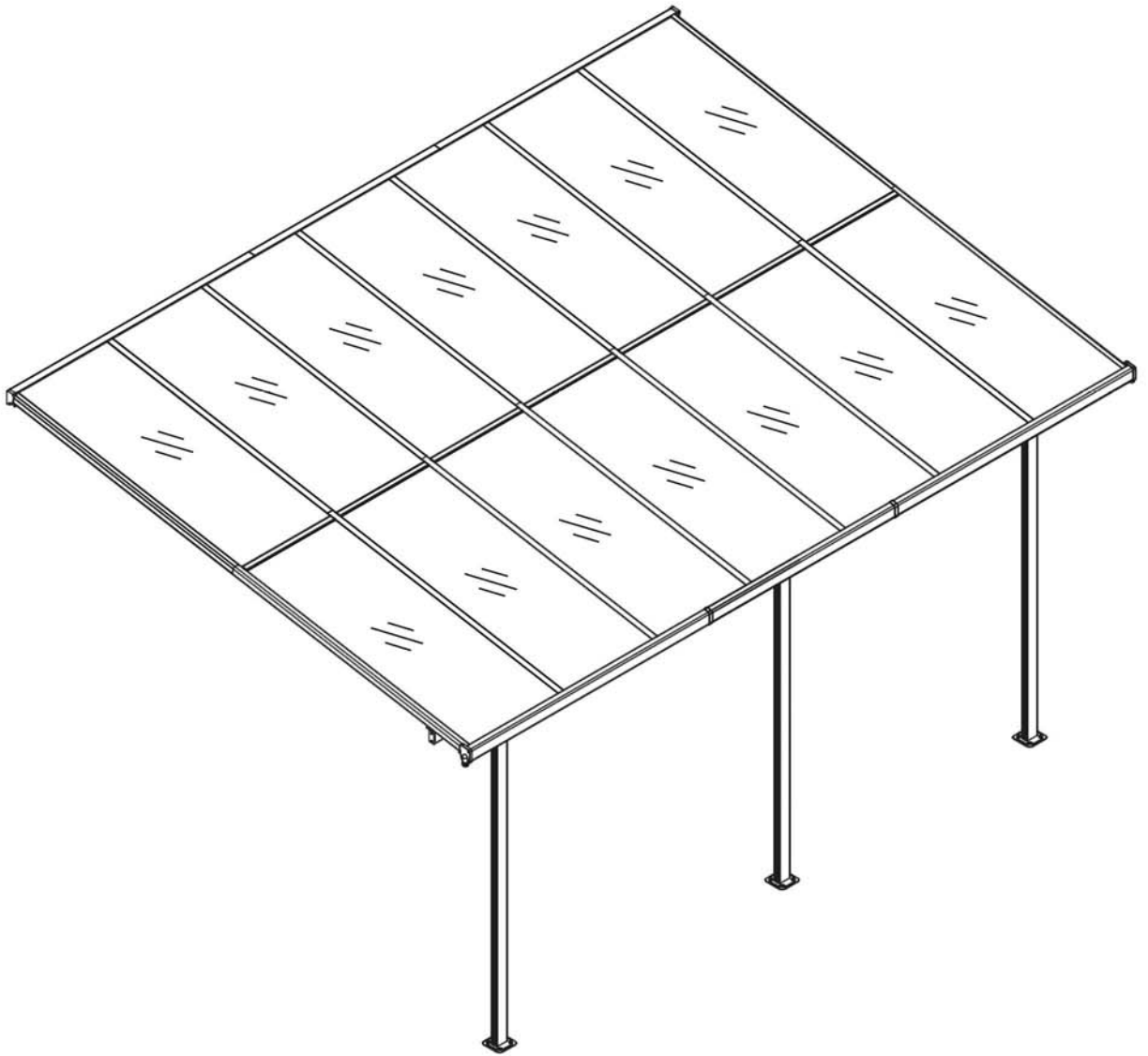













## Safety must be put in the No. 1 position:

- 1 Select a dry and calm day for your assembly. Team works ( Two or more people ) are required during the assembly;
- 2 Wearing safety gloves, eye protection and long sleeves during the assembly to prevent injury; Pay attention to the sharp edge of some parts;
- 3 Children and pets are not allowed entering into the construction site;
- 4 Never concentrate your total weight on the roof of the building. When using a step ladder make sure that it is safety;

## Care & Maintenance:

- 1 Keep the shed clean with soft cloth, use water if necessary;
- 2 Keep the door tracks clear of dirt and other stuff that prevent them from sliding easily.
- 3 Clean the snow with necessary tools to make sure it is safe to enter into; Heavy snow may cause collapse, please make sure safety before entering into.
- 4 The shed is not made for living but storing stuff.
- 5 Please add some oil on the top and bottom door sliding channel to make door slides smoothly.



Name of parts	Section	QTY(pcs)
<b>Box 1/4</b>		
Bd-A19		6
Bd-A19b		6
Bd-A12a		1
Bd-A12b		1
Bd-A12c		1
Bd-A20		2
Bd-A20b		2
<b>Box 2/4</b>		
Bd-A24a		1
Bd-A24b		1
Bd-A24c		1
Bd-A5a		1
Bd-A5b		1
Bd-A5c		1
Bd-8		3
Bd-12		2
Bd-19		6
Bd-20		2
Bd-14		7
Bd-4		6
Ba-2		2
Bd-1		3
Bd-P6		2
Bd-P3L		1

Name of parts	Section	QTY(pcs)
Bd-P3R		1
Bd-P1L		1
Bd-P1R		1
Bd-P2L		1
Bd-P2R		1
Bd-P5		2
Bd-F27		70 +2
Bd-F28		70 +2
Bd-F29		40 +2
Bd-F30		6 +2
Bd-F31		12
Bd-F32		6 +2
Bd-F33		12 +2
Instruction manual		1
Bd-F34		8 +2
Bd-F35		12 +2
<b>Box 3/4</b>		
Bd-A23		7
<b>Box 4/4</b>		
Bd-A23		7



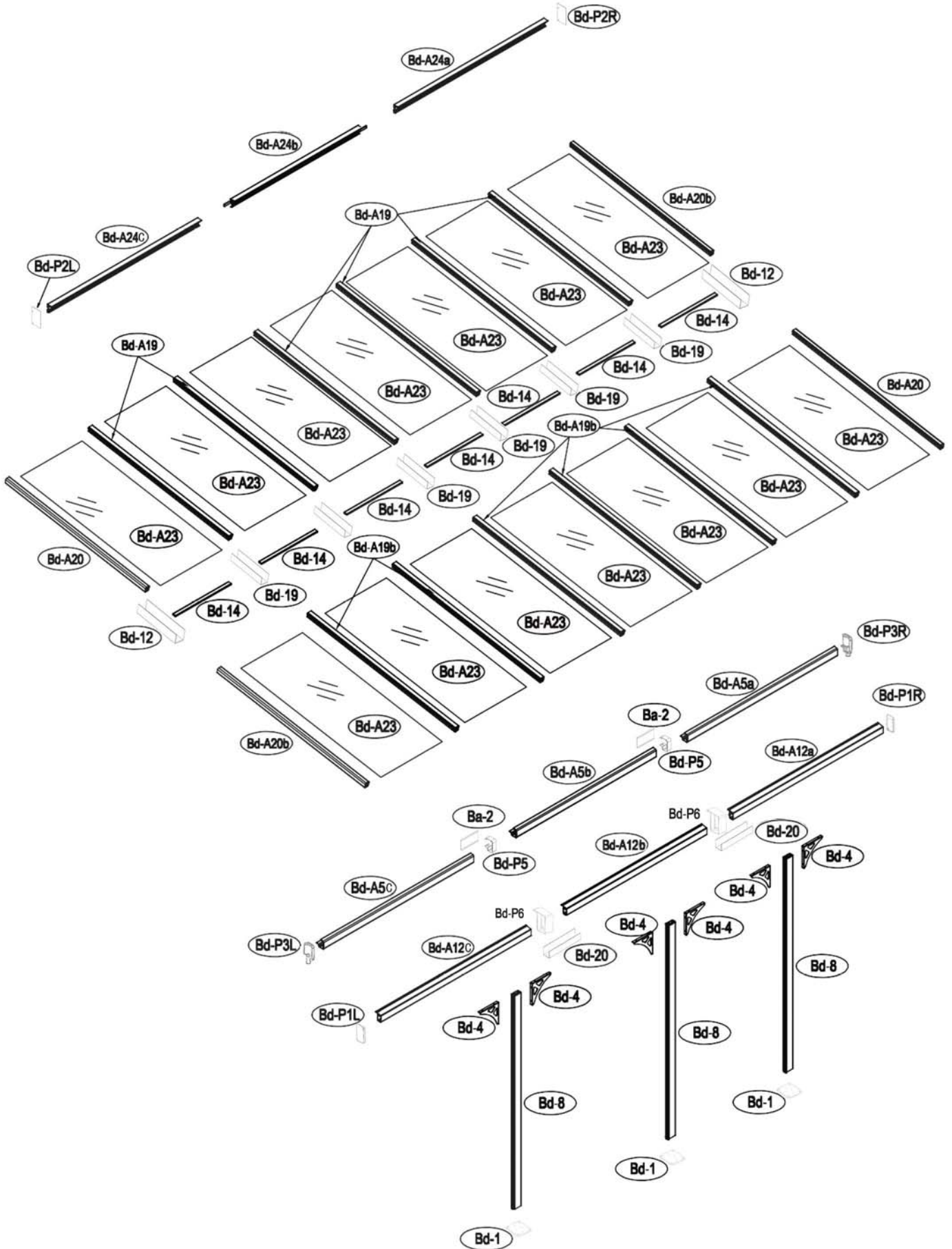



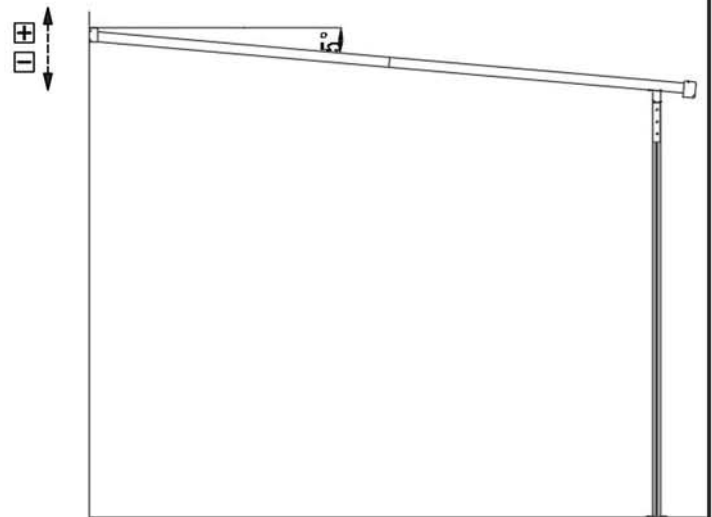
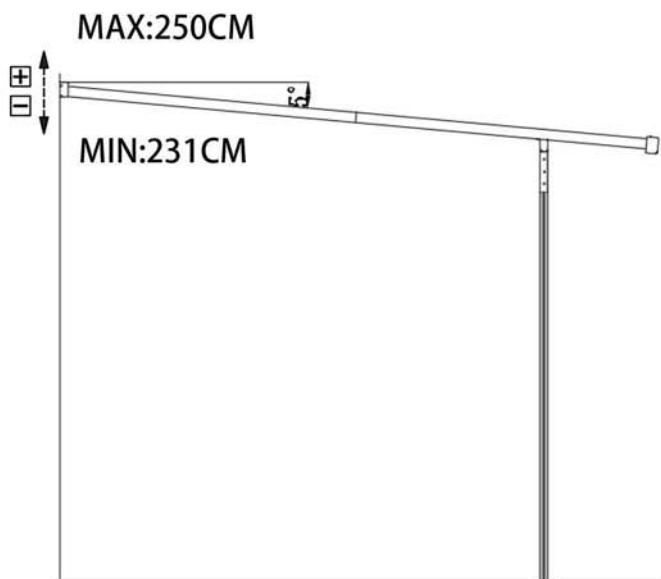
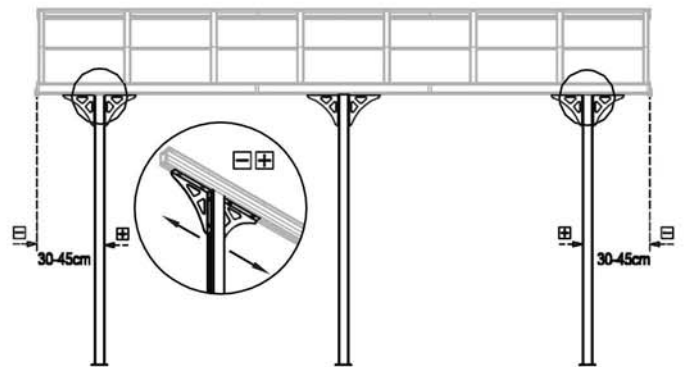
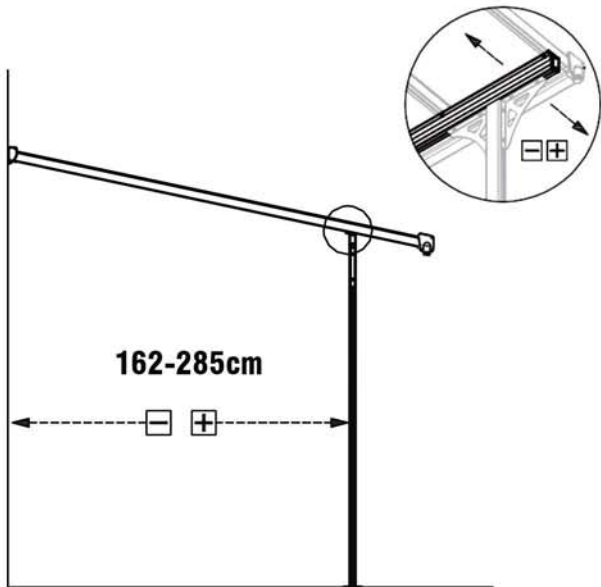
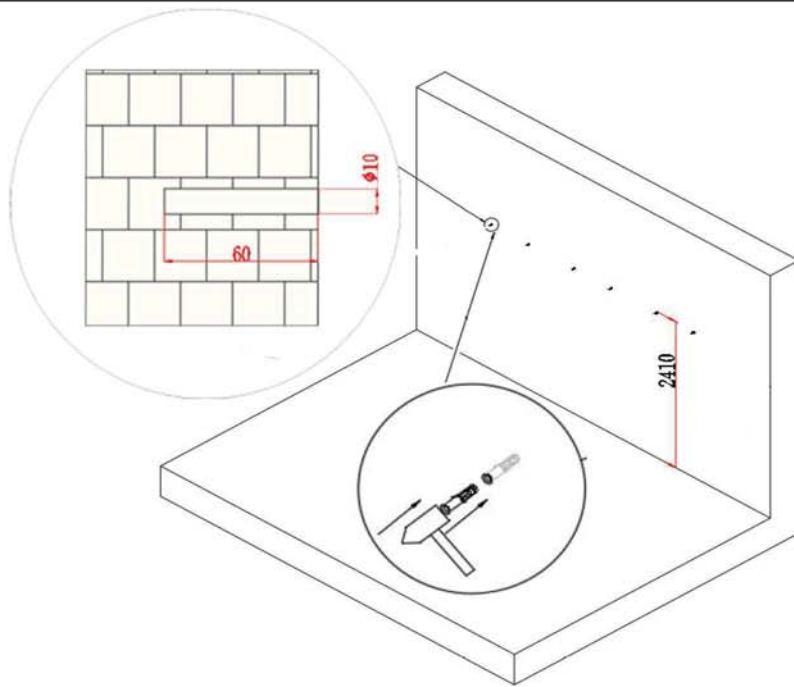

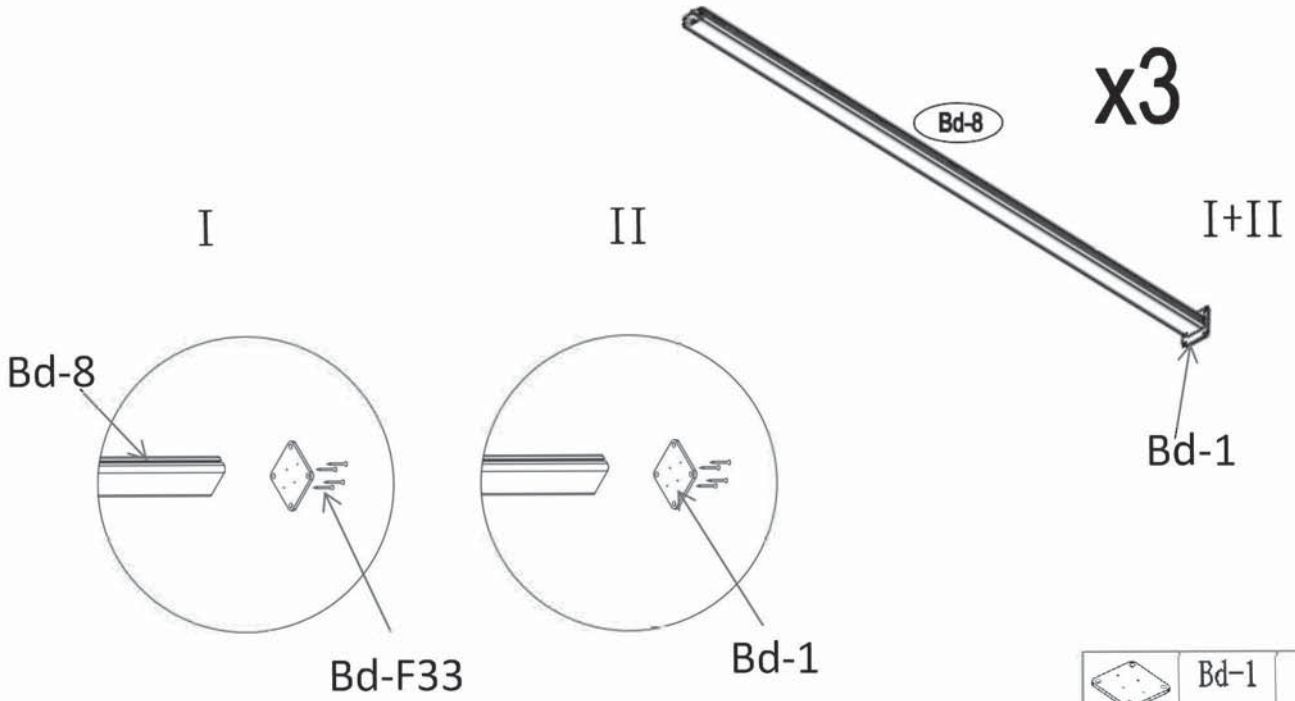

	Bd-1	3
	Bd-8	3
	Bd-F33	12

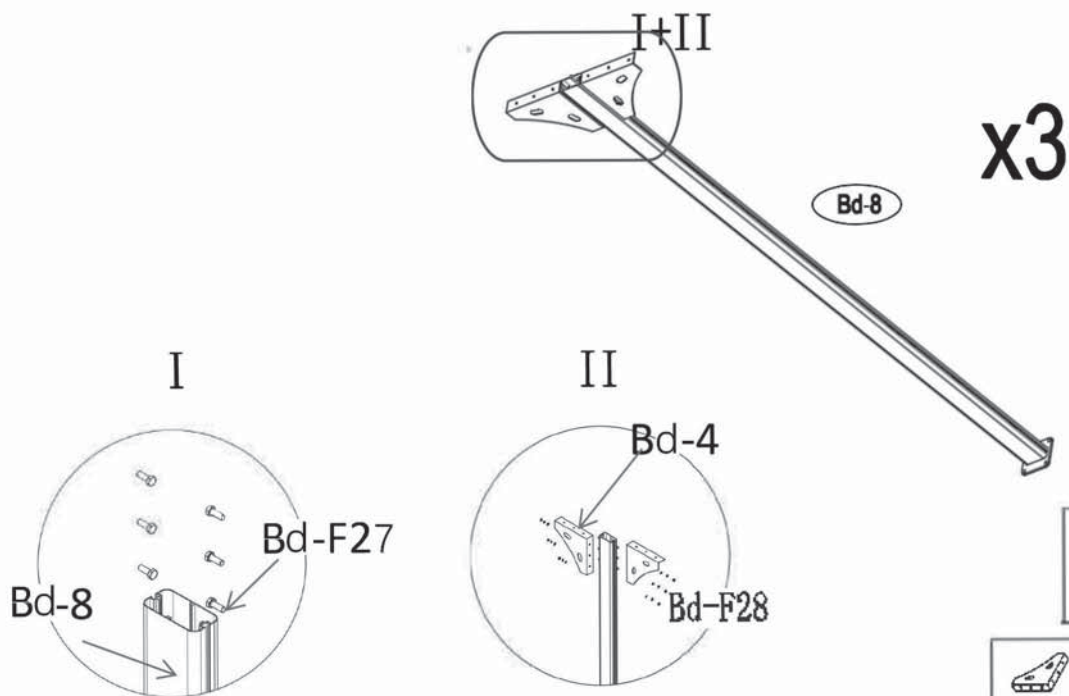

	Bd-4	6
	Bd-8	3
	Bd-F27	18
	Bd-F28	18



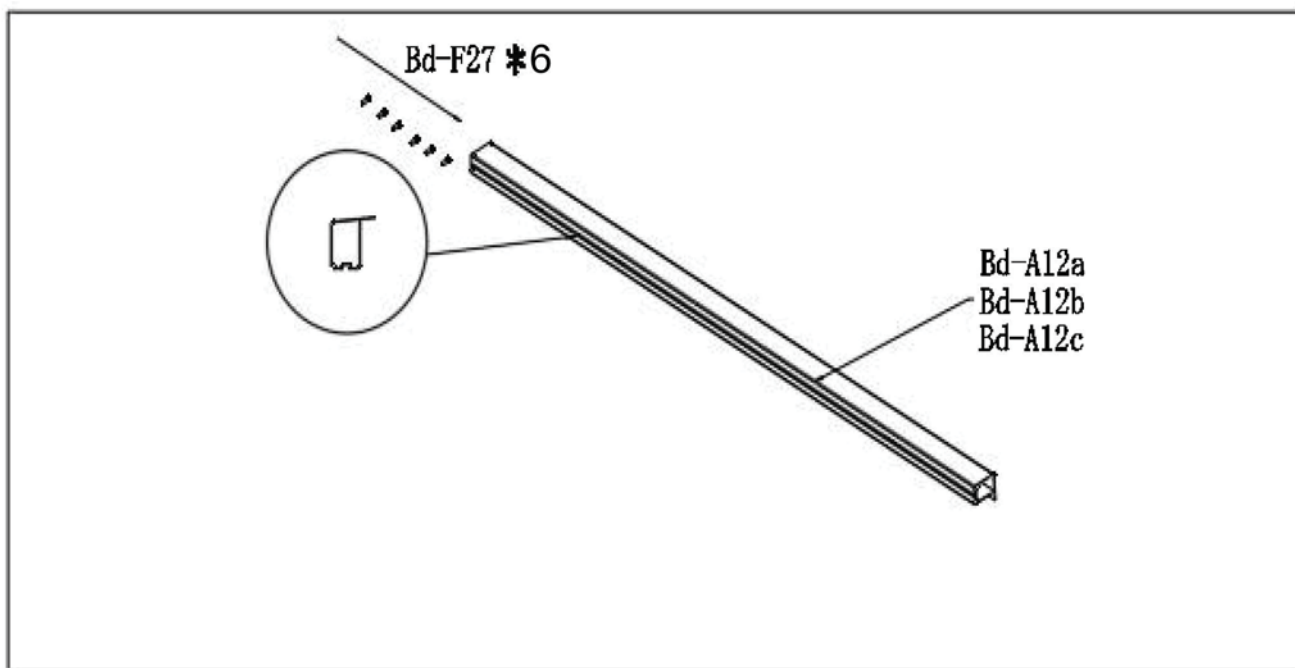

	Bd-A12a	1
	Bd-A12b	1
	Bd-A12c	1
	Bd-F27	18

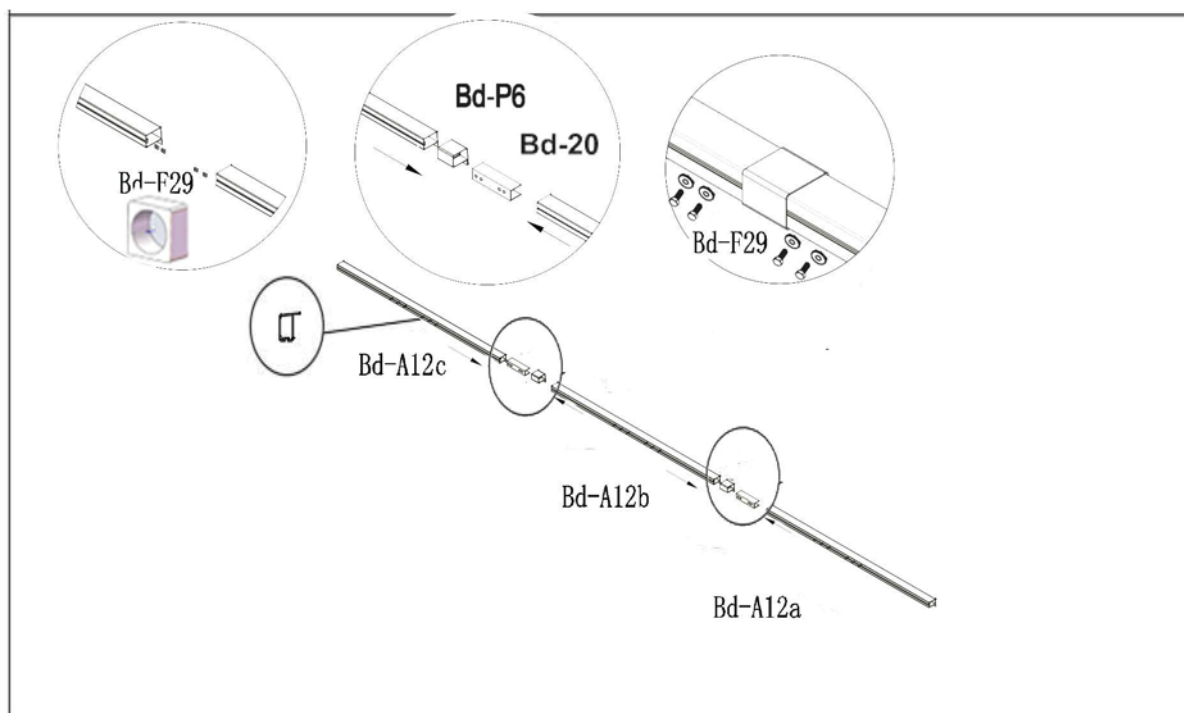



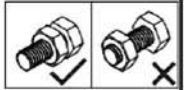
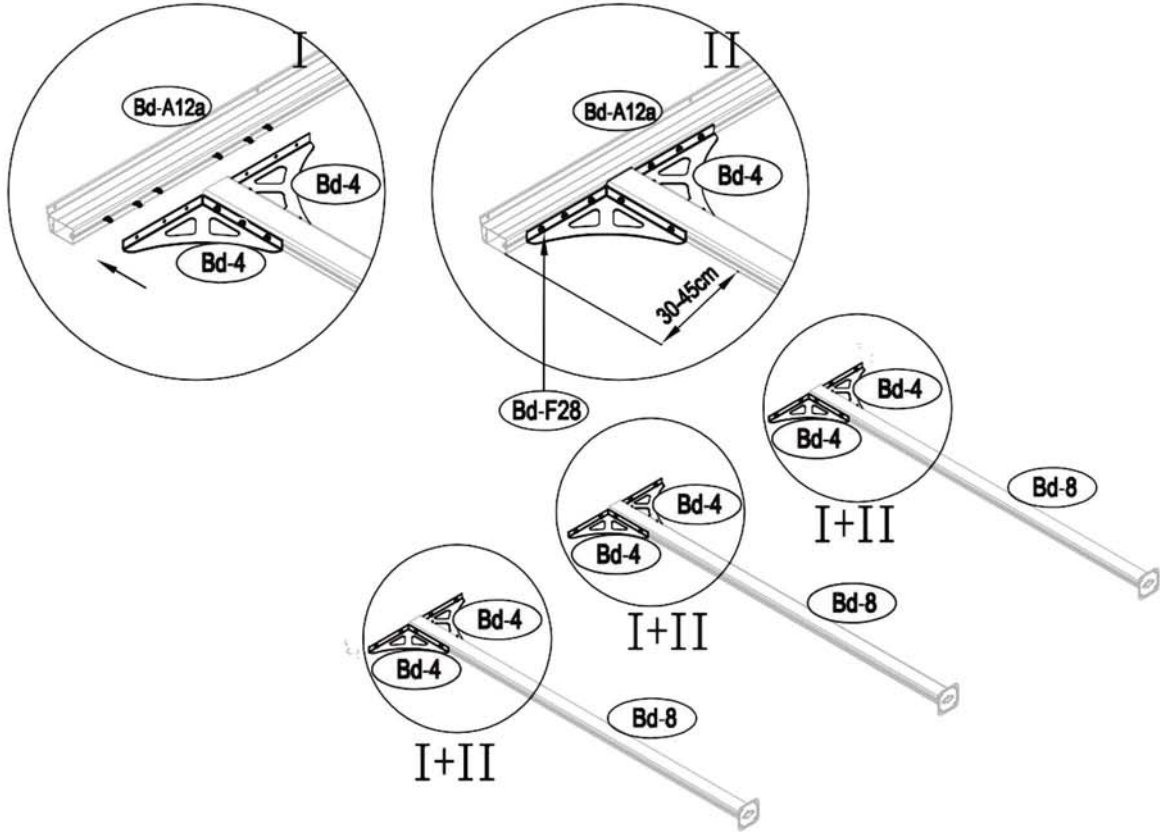
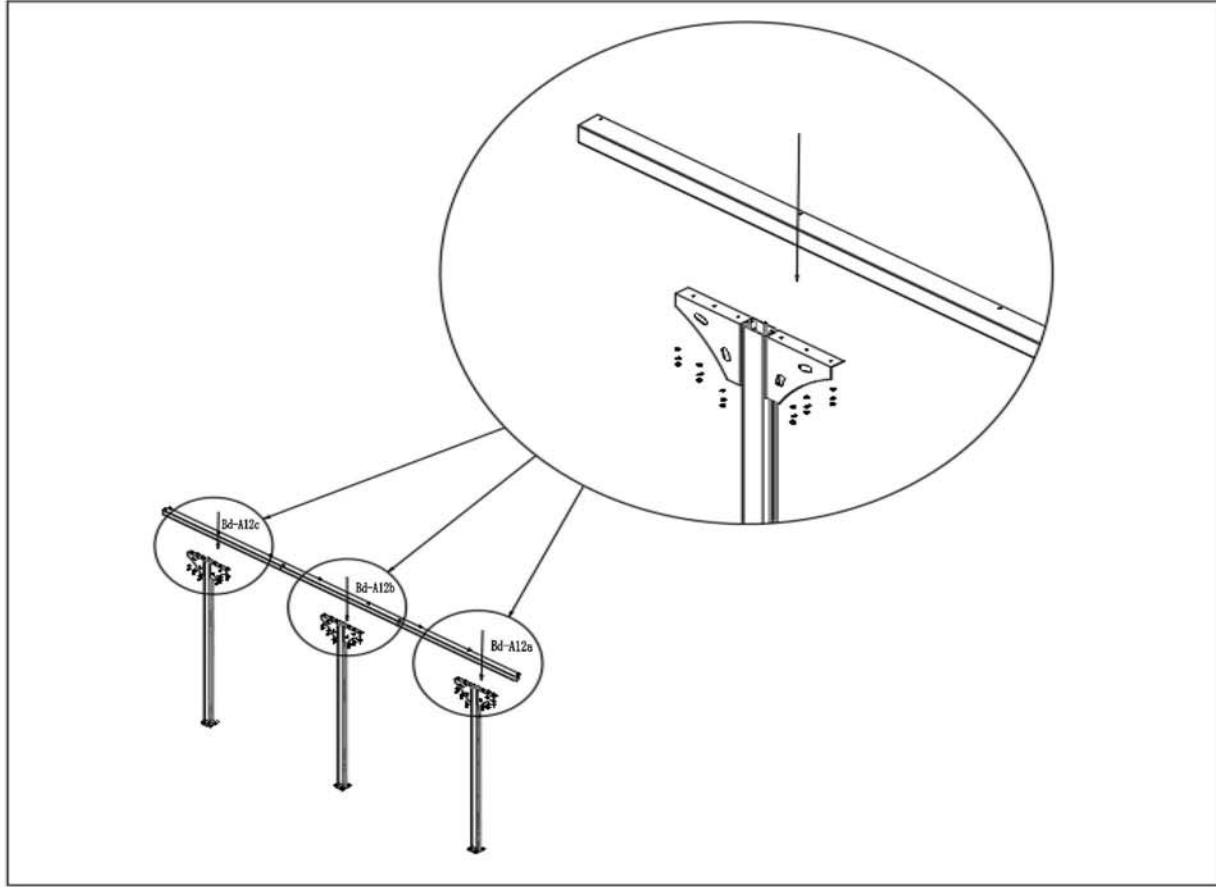

	<b>Bd-20</b>	<b>2</b>
	Bd-A12a	1
	Bd-A12b	1
	Bd-A12c	1
	Bd-F29	8
	<b>Bd-P6</b>	<b>2</b>



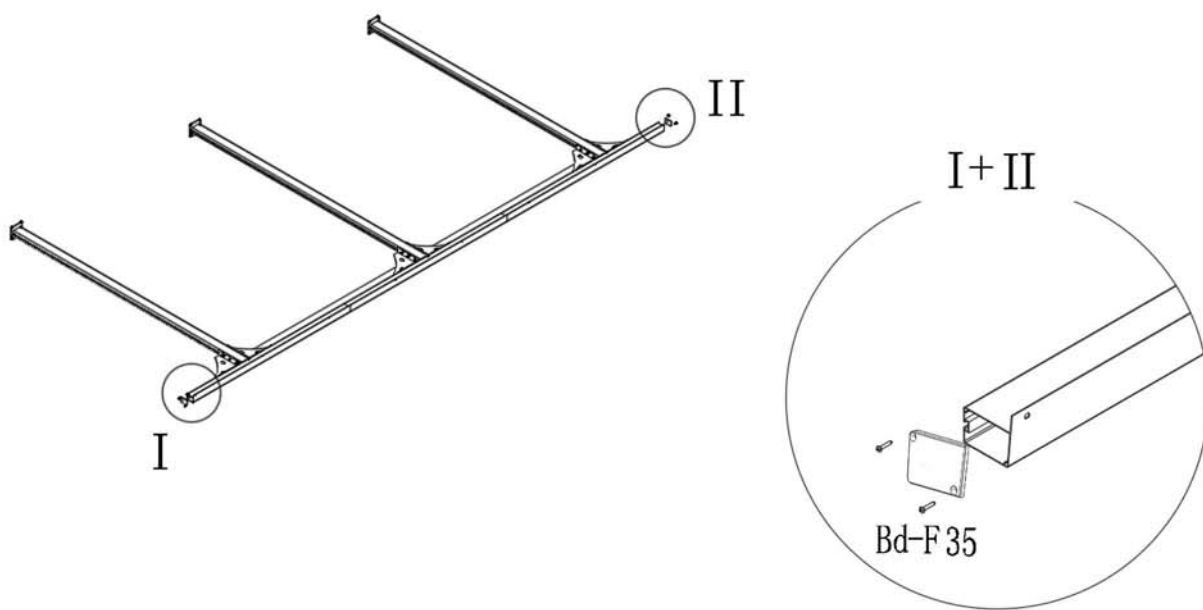





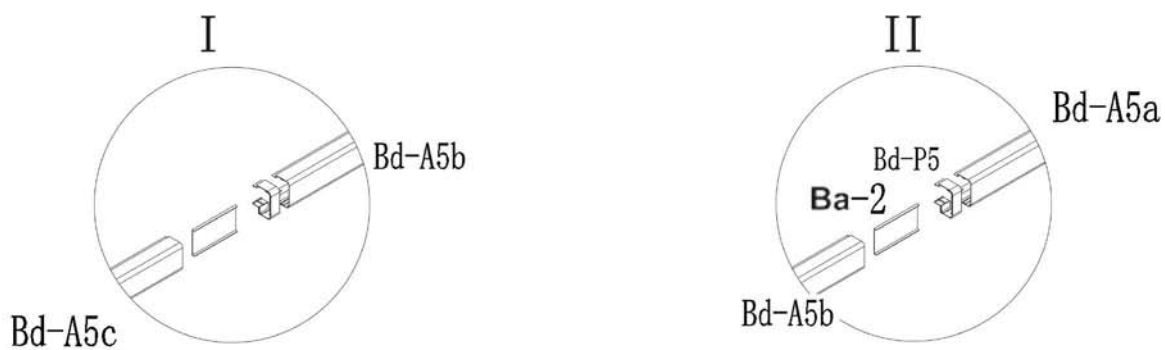

	Bd-8	3
	Bd-F28	18



	Bd-P1L	1
	Bd-P1R	1
	Bd-F 35	4



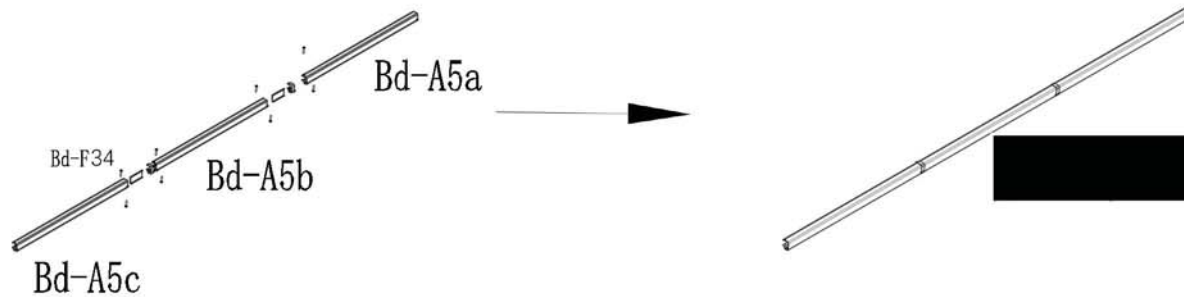
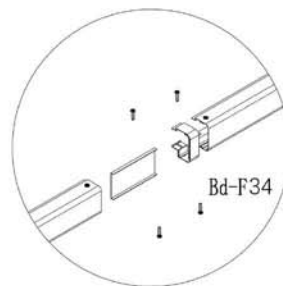
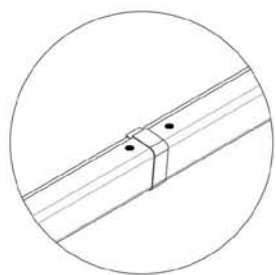

	Bd-P5	2
	<b>Ba-2</b>	2
	Bd-A5a	1
	Bd-A5b	1
	Bd-A5c	1

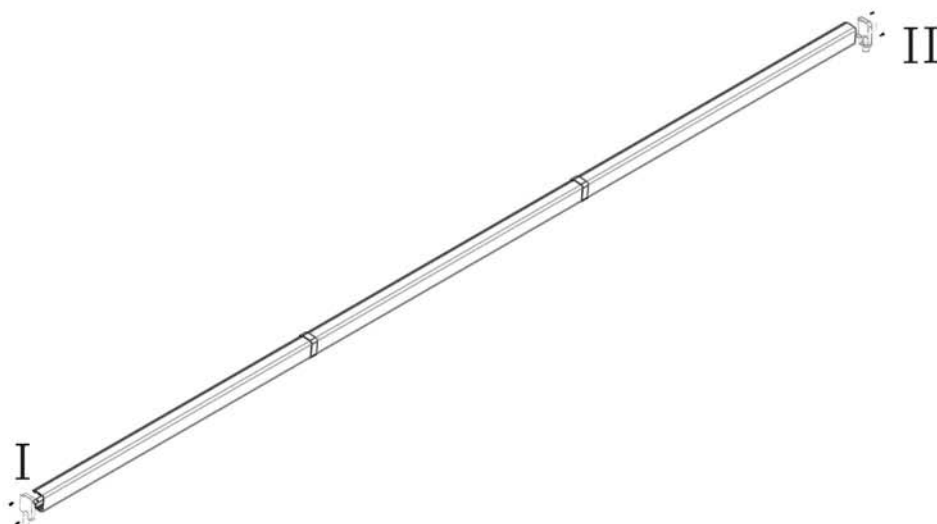
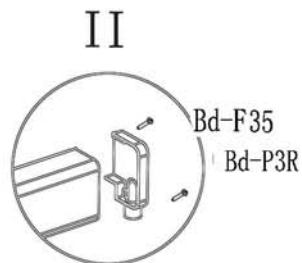
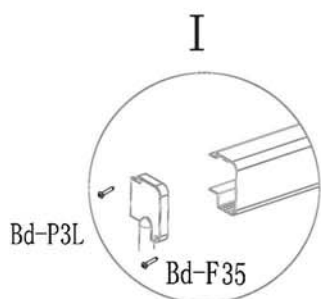

	Bd-F34	8
---	--------	---



	Bd-P3L	1
	Bd-P3R	1
	Bd-F35	4

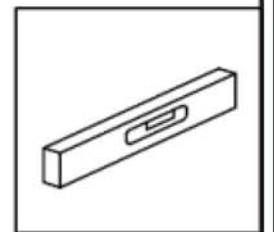
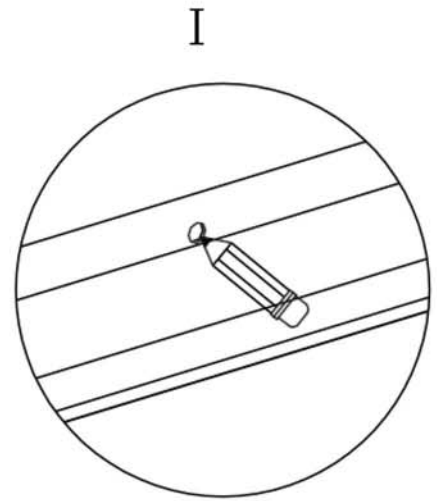
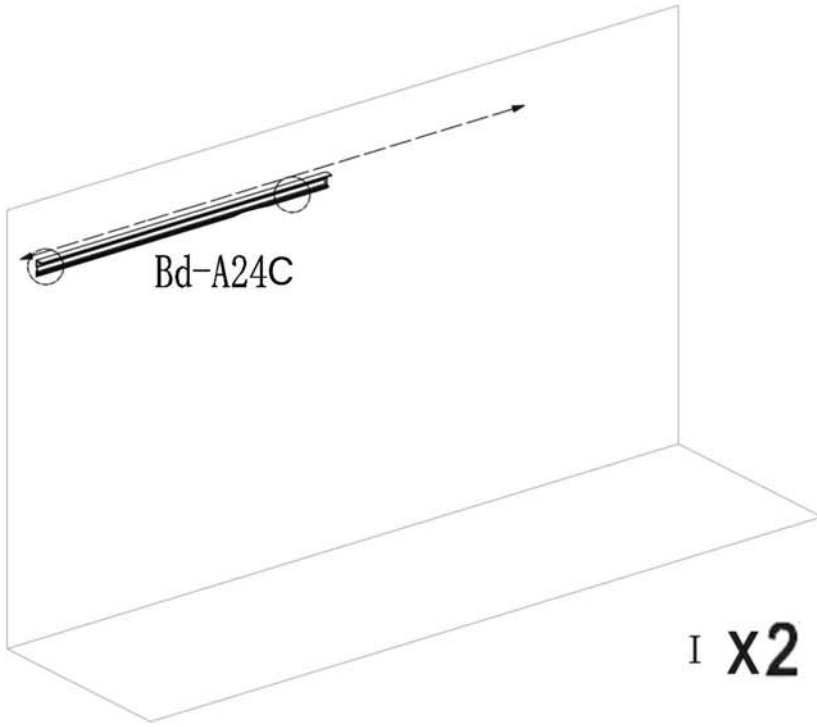

	Bd-A24C	1
--	---------	---

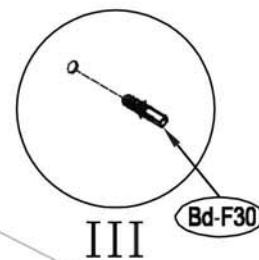
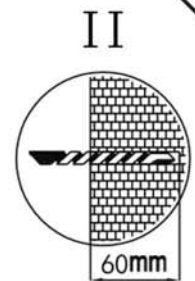
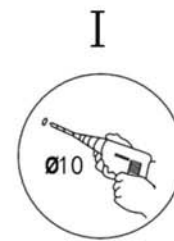
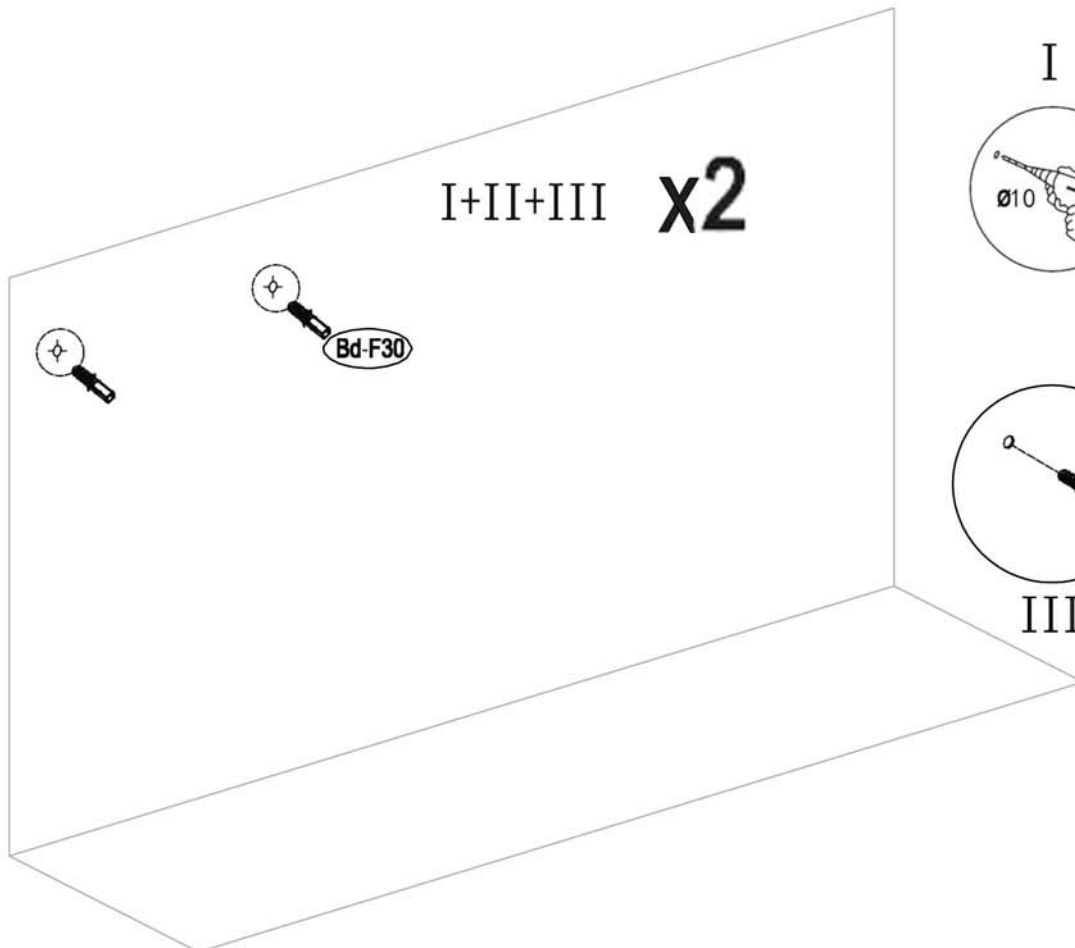

Bd-F30		x2
--------	--	----



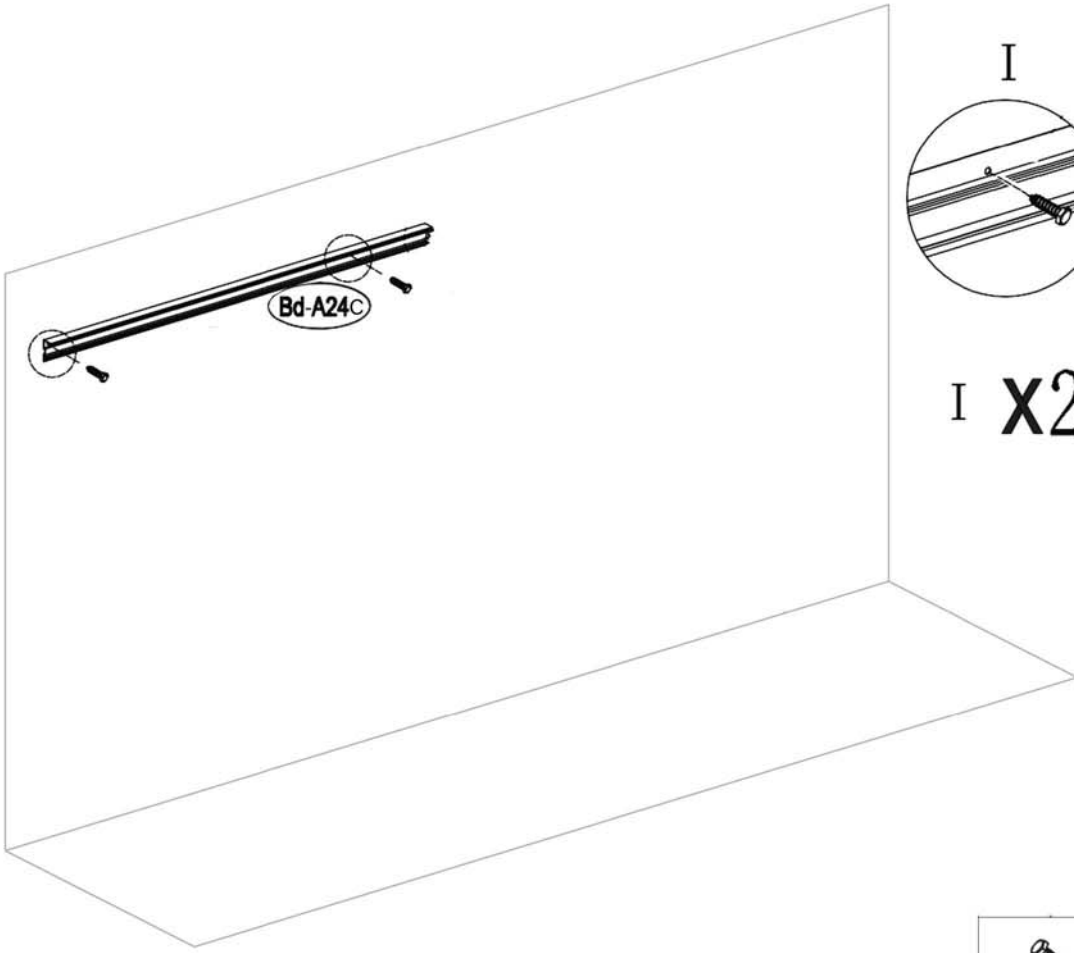

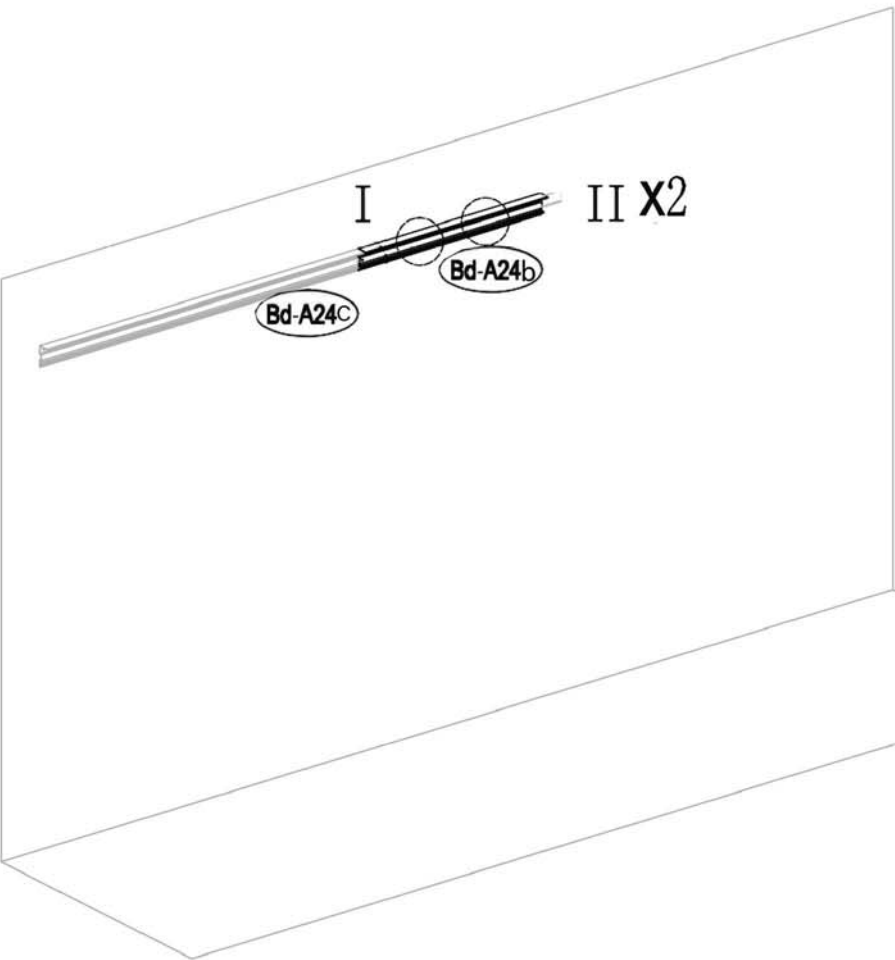

I X2

	Bd-F32	2
---	--------	---

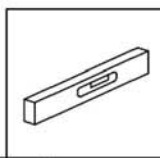
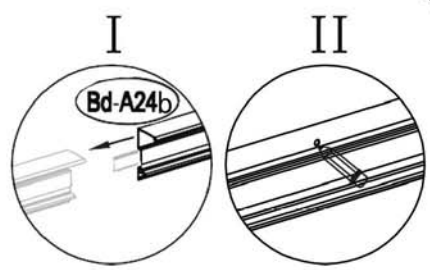

I II X2



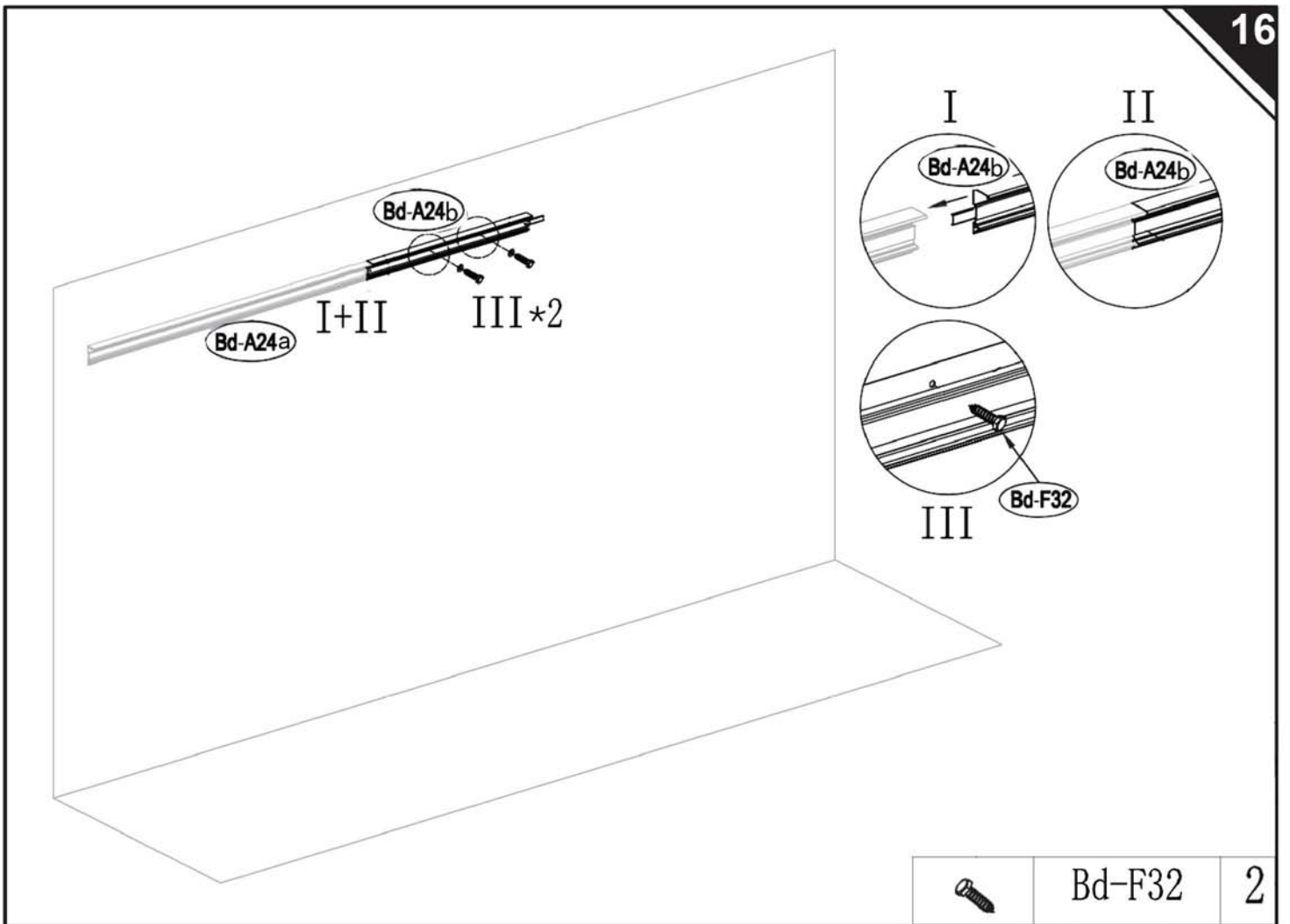
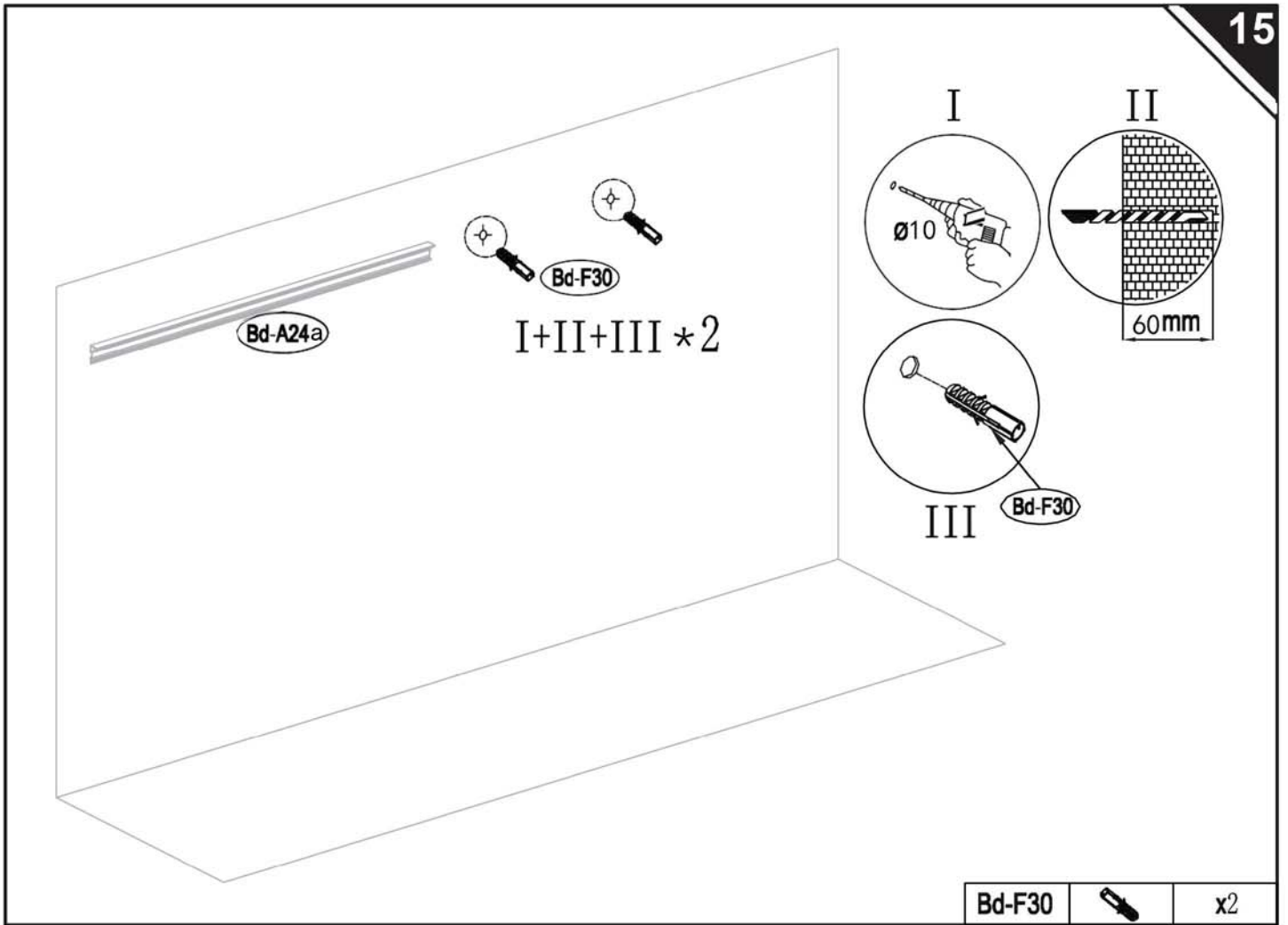

Bd-A24b		x1
---------	---	----

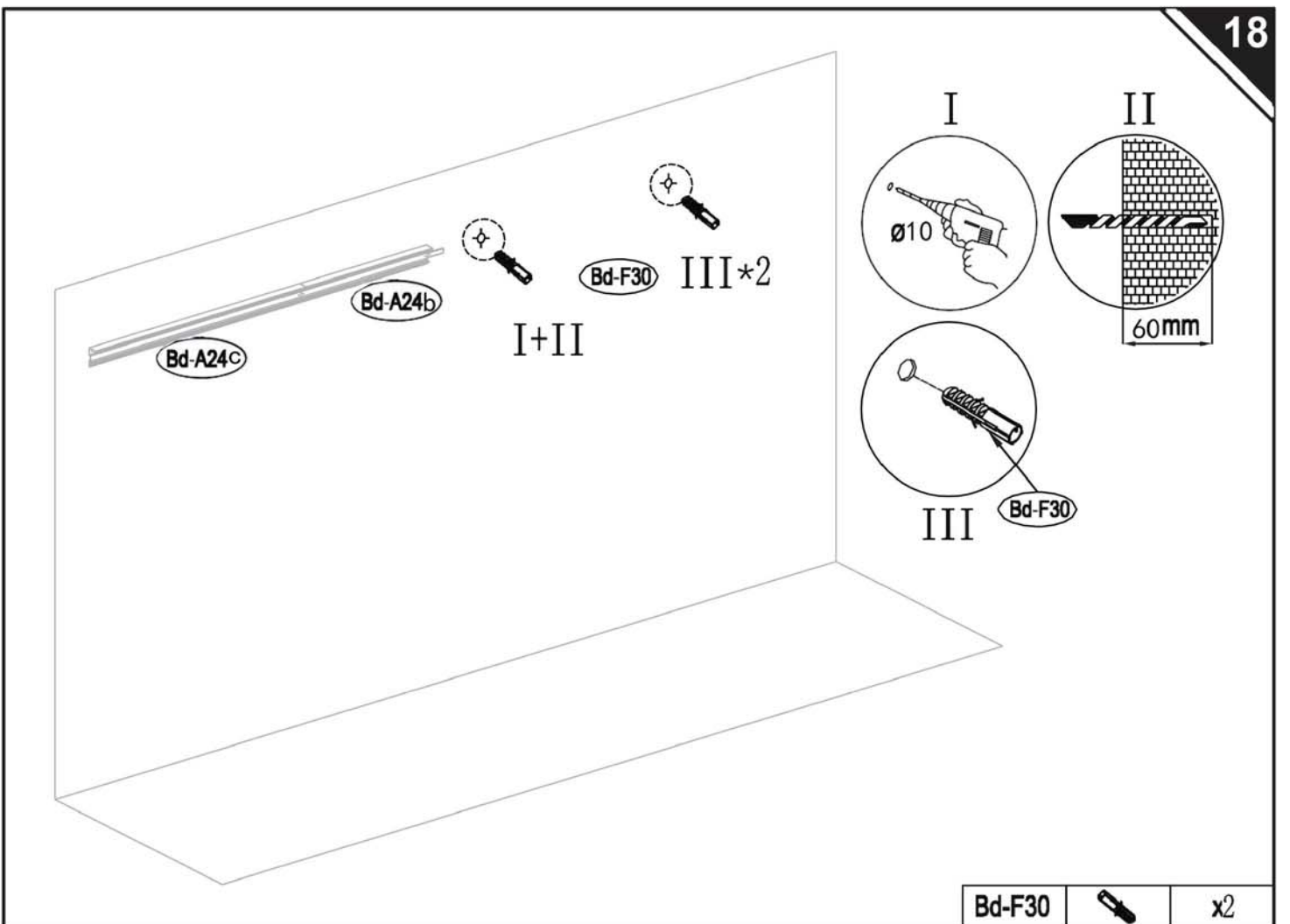
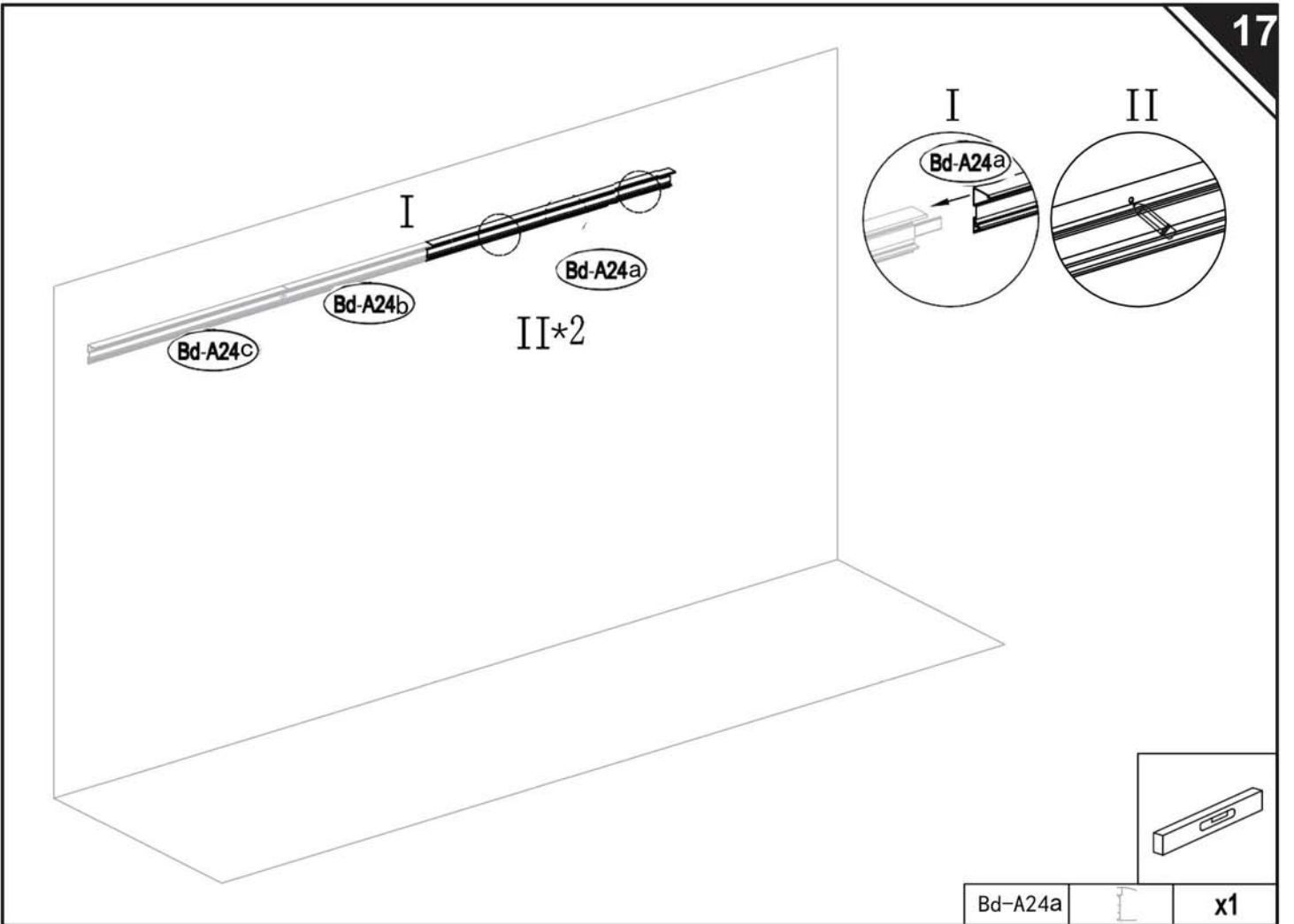

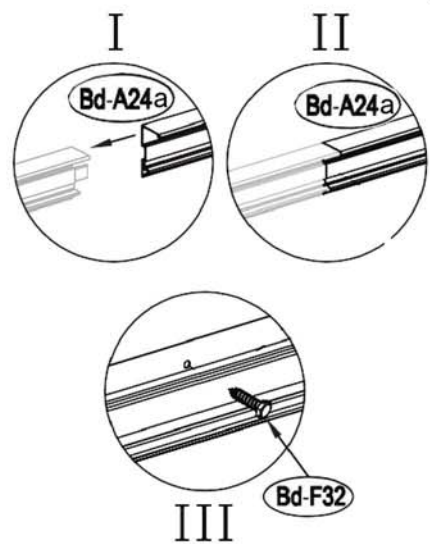
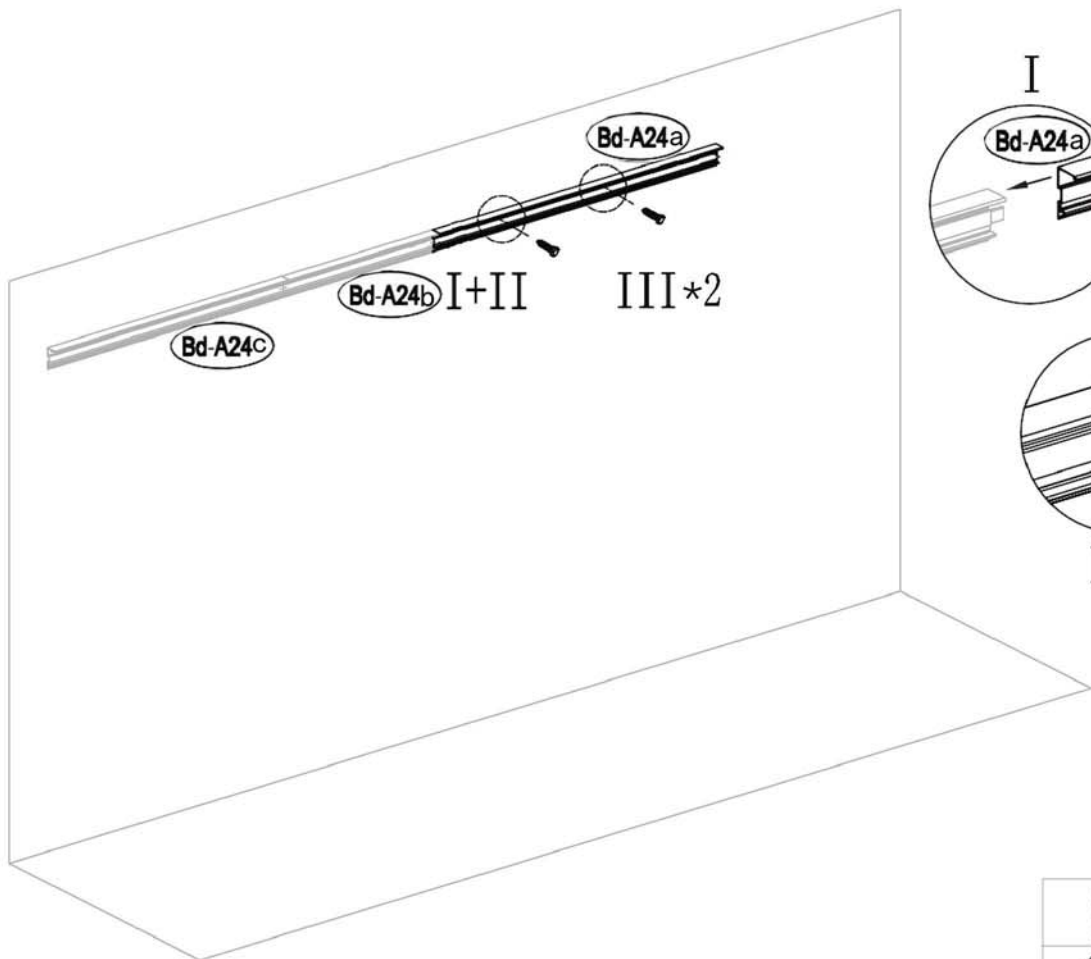



	Bd-A24a	1
	Bd-F32	2

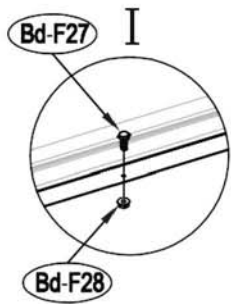
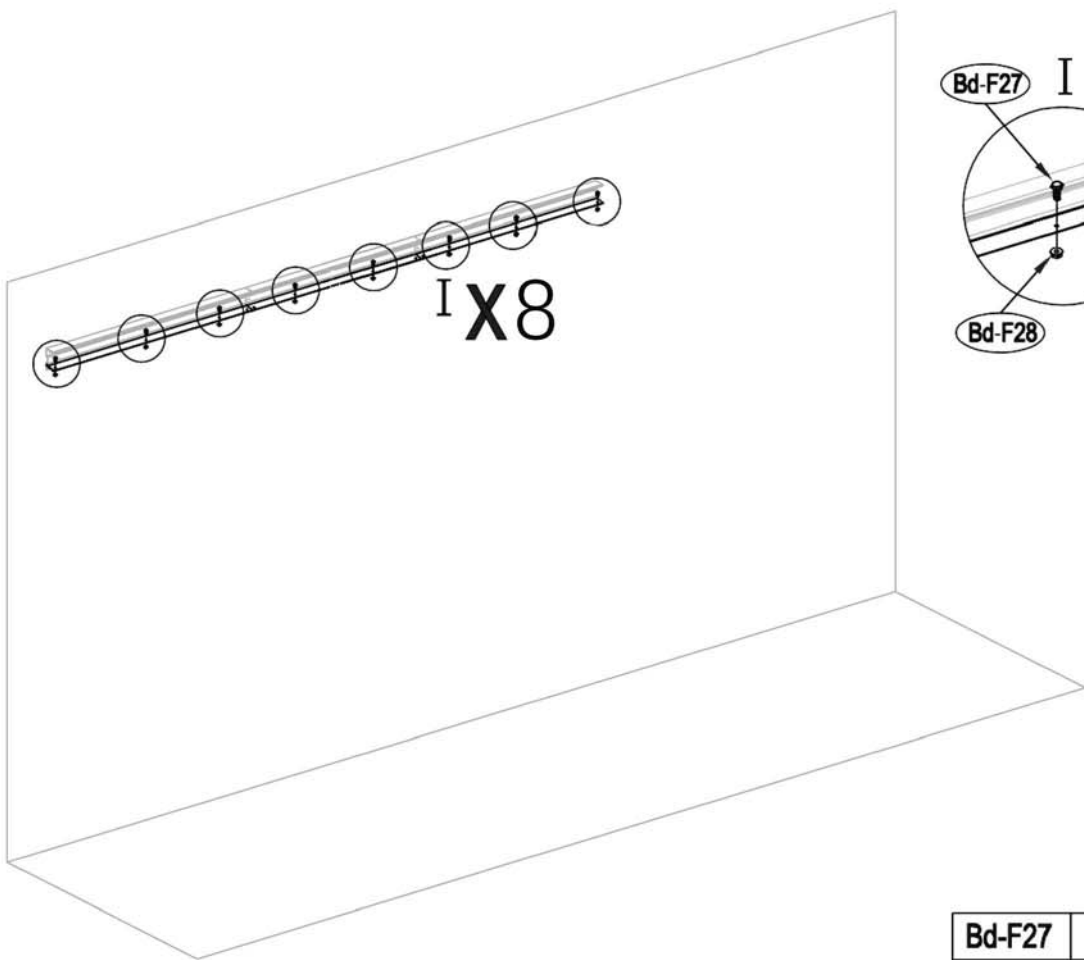

		
Bd-F27		x 8
Bd-F28		x 8

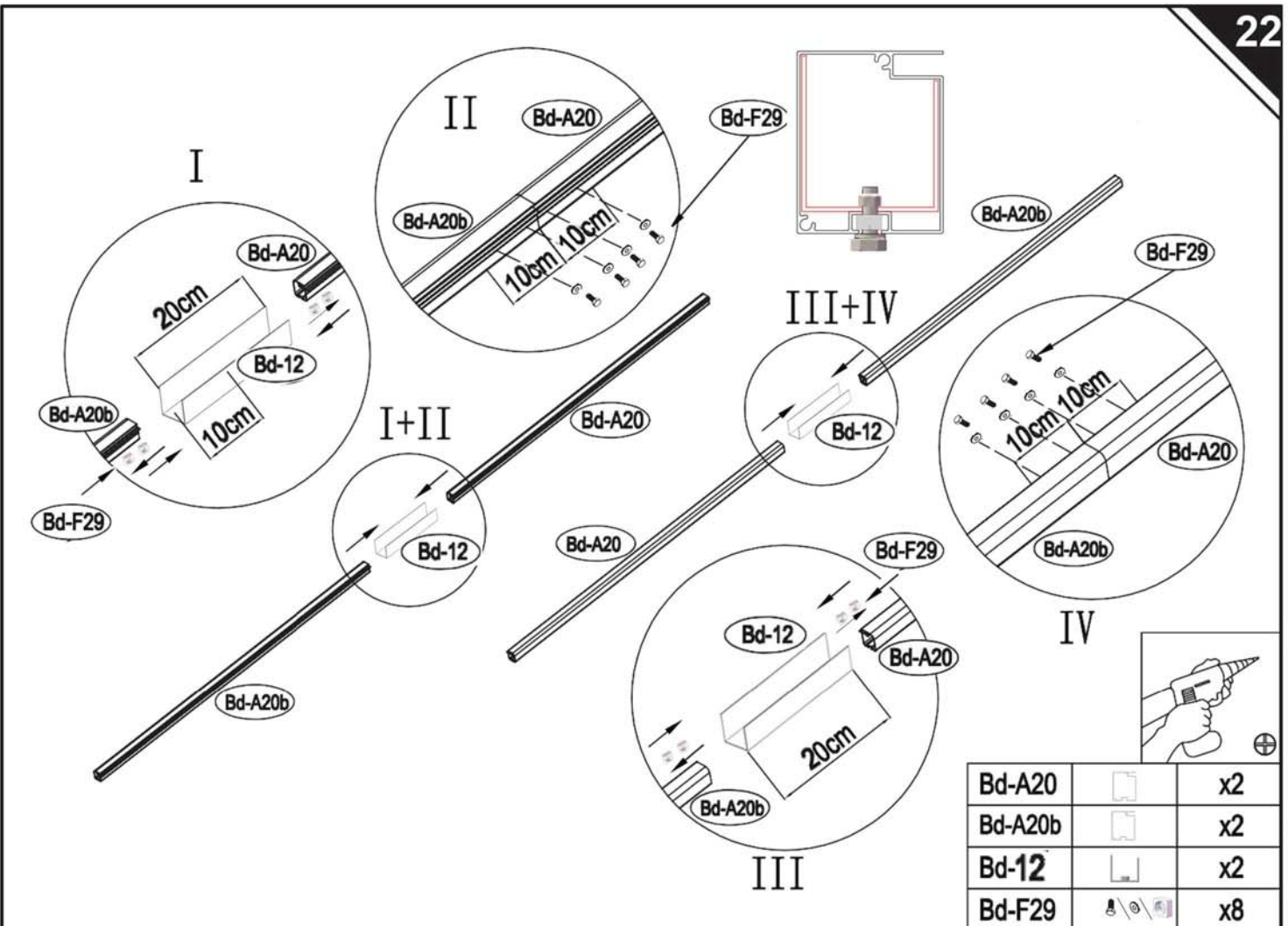
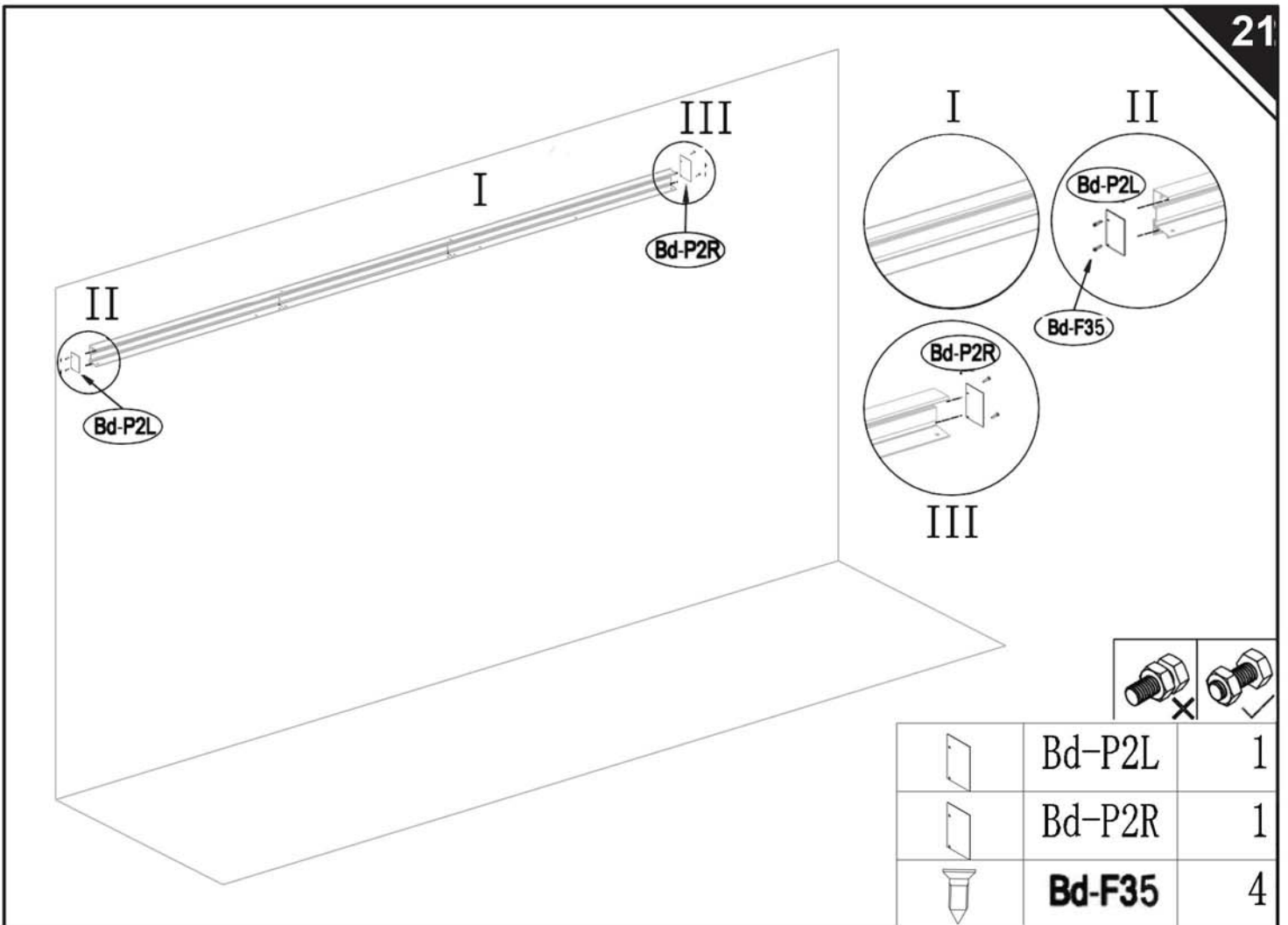



x6

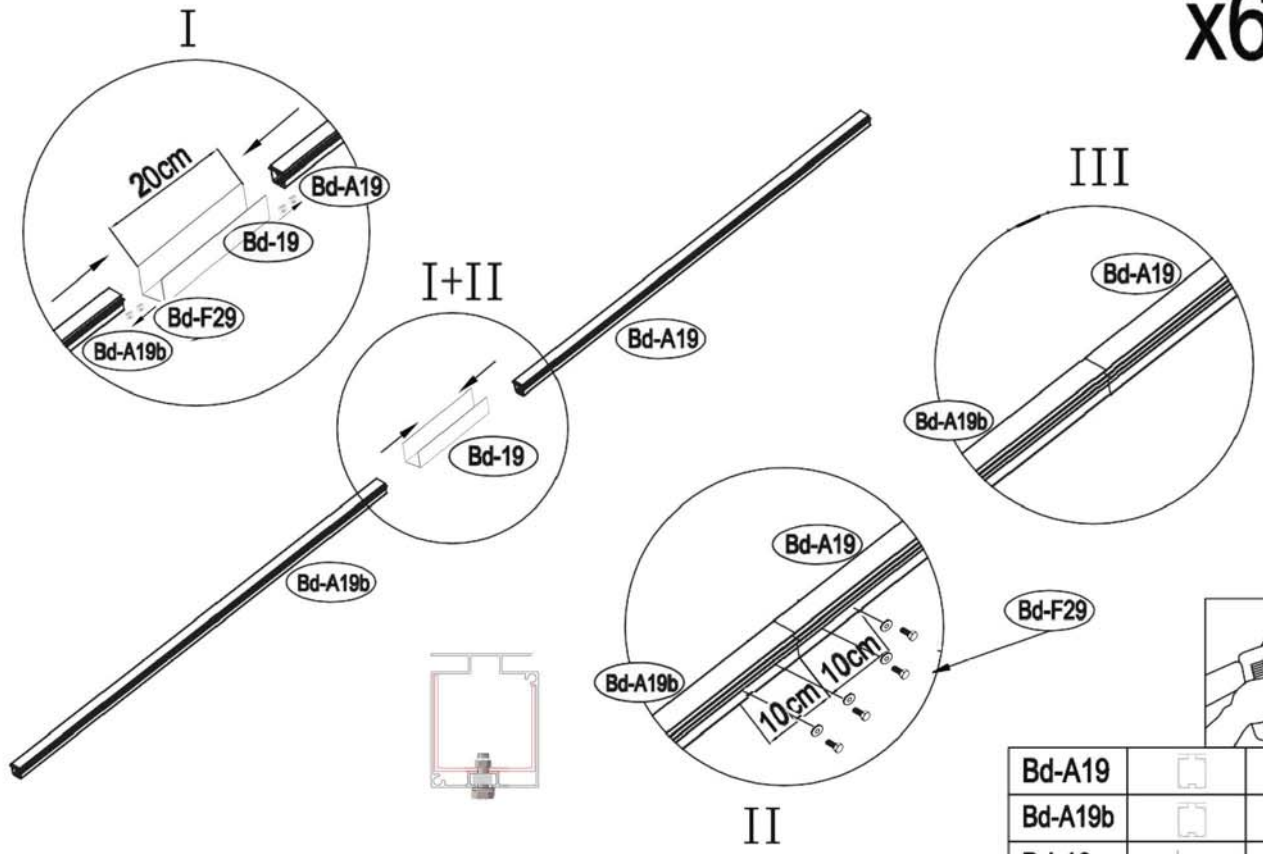

Bd-A19		x6
Bd-A19b		x6
Bd-19		x6
Bd-F29		x24

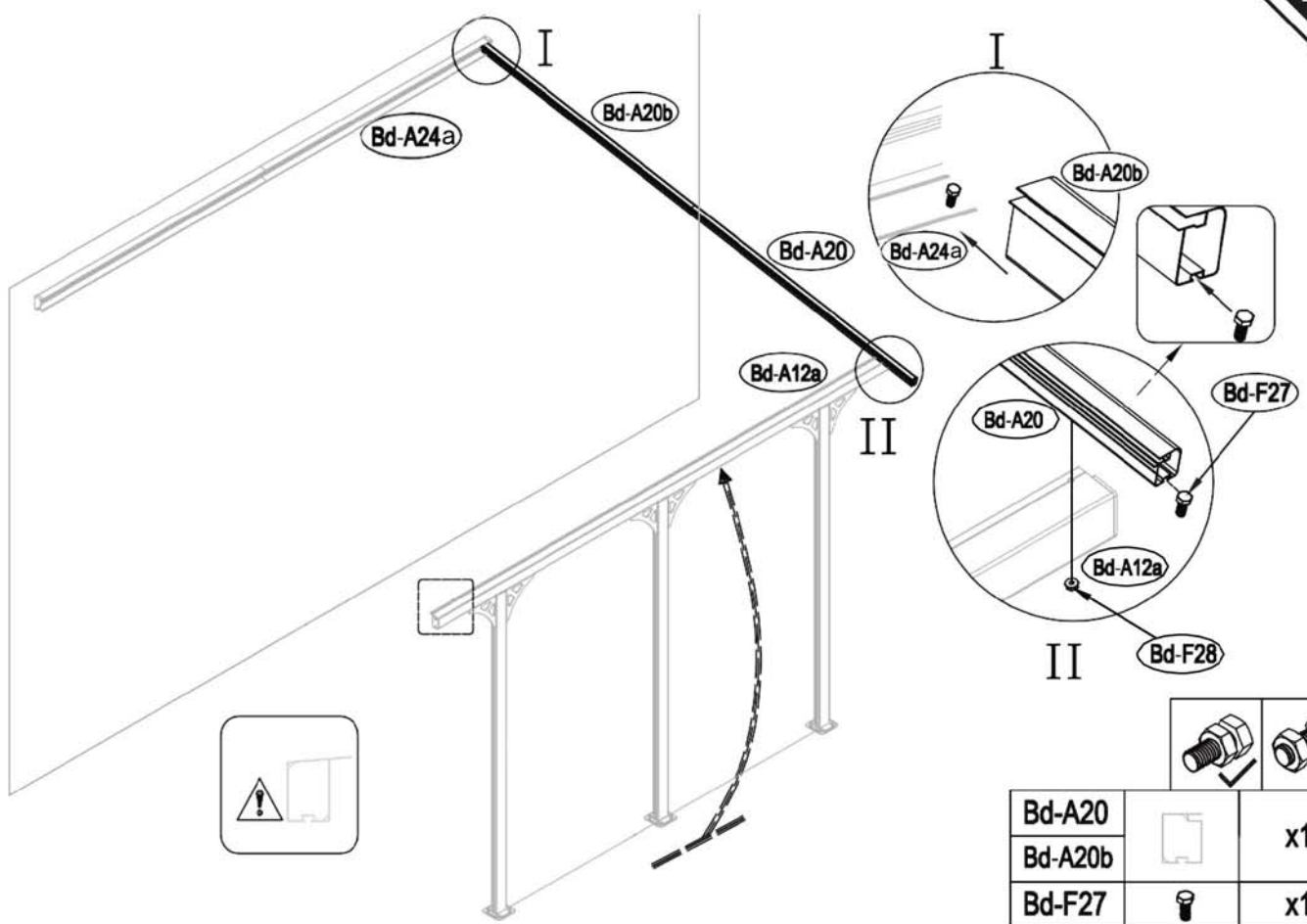

Bd-A20		x1
Bd-A20b		x1
Bd-F27		x1
Bd-F28		x1

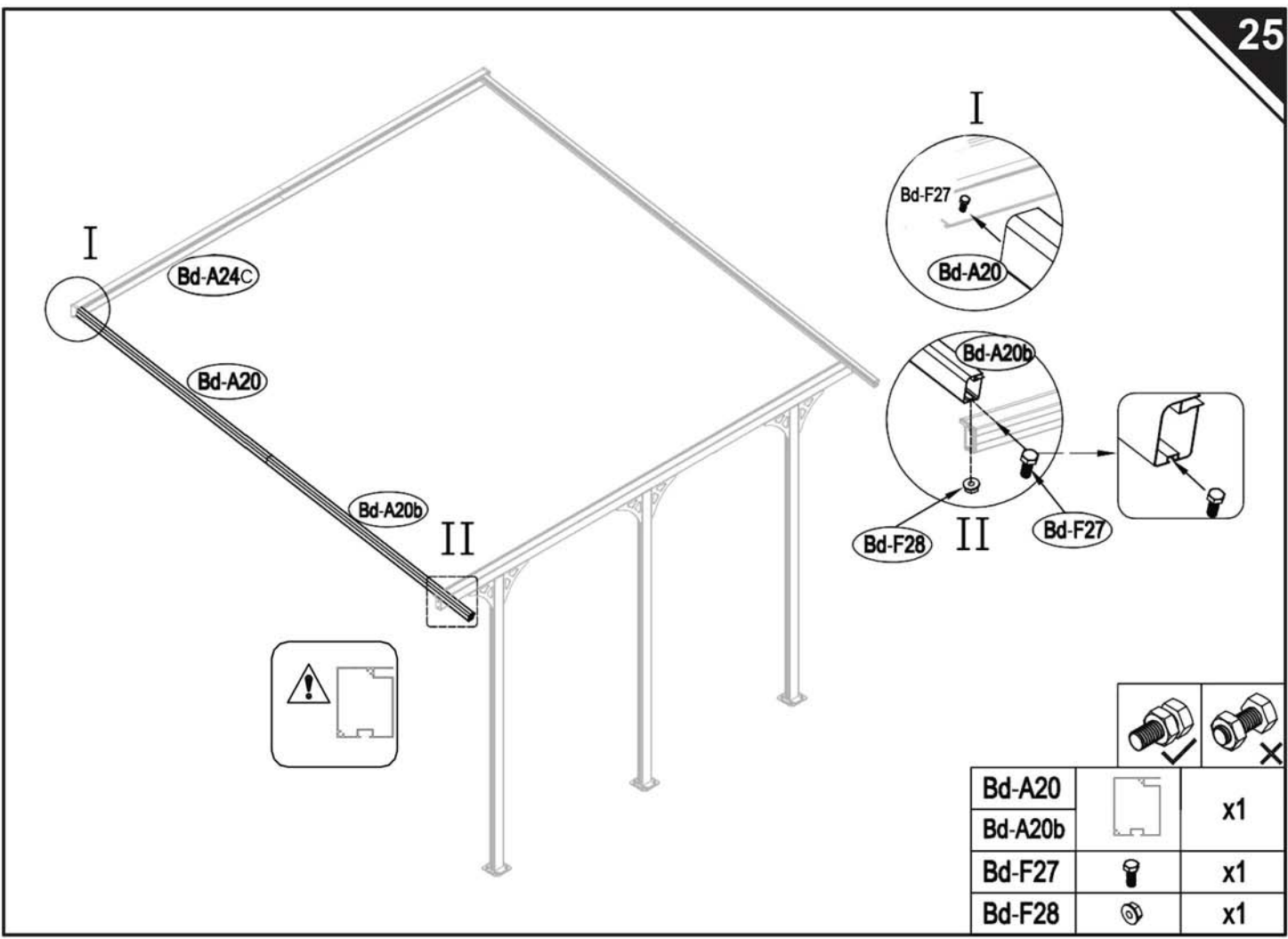

Bd-A20		x1
Bd-A20b		x1
Bd-F27		x1
Bd-F28		x1

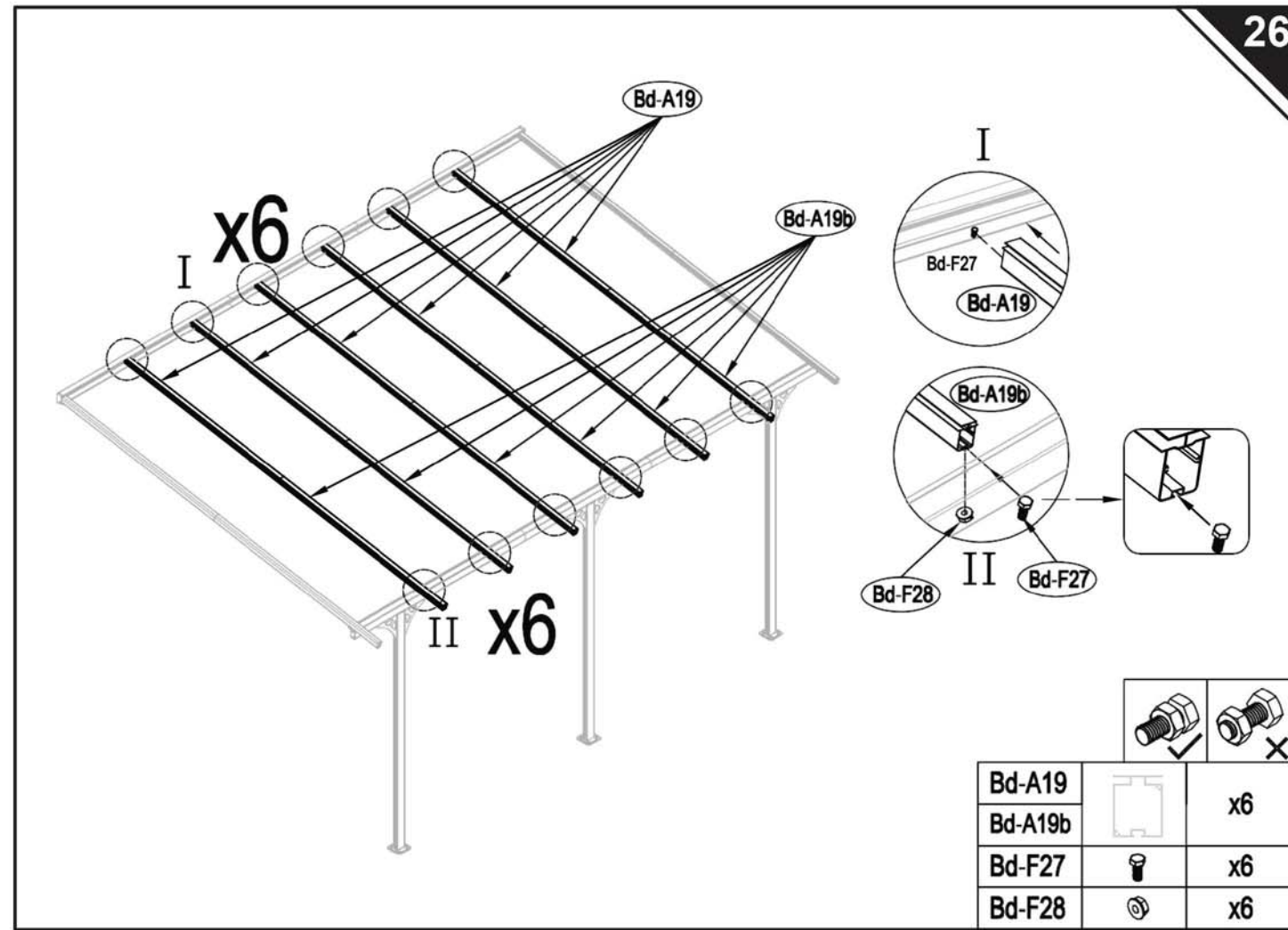

Bd-A19		x6
Bd-A19b		x6
Bd-F27		x6
Bd-F28		x6

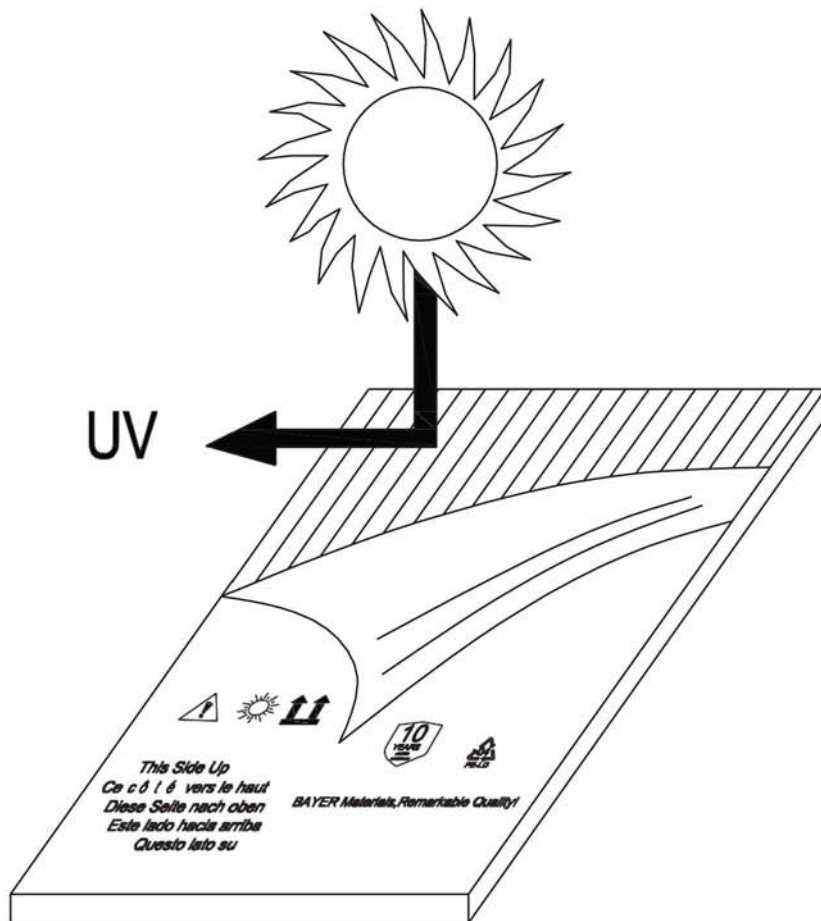

Bd-A23  x14

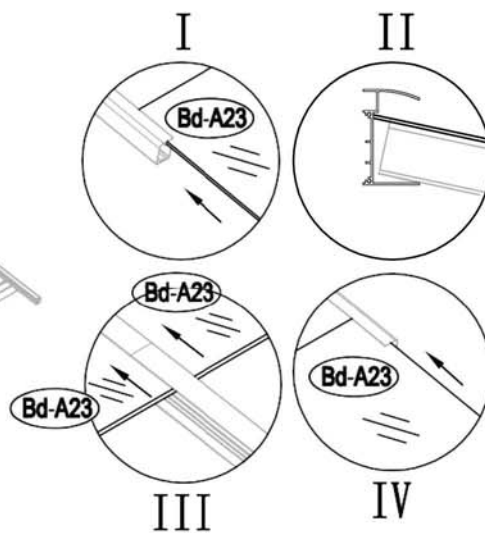
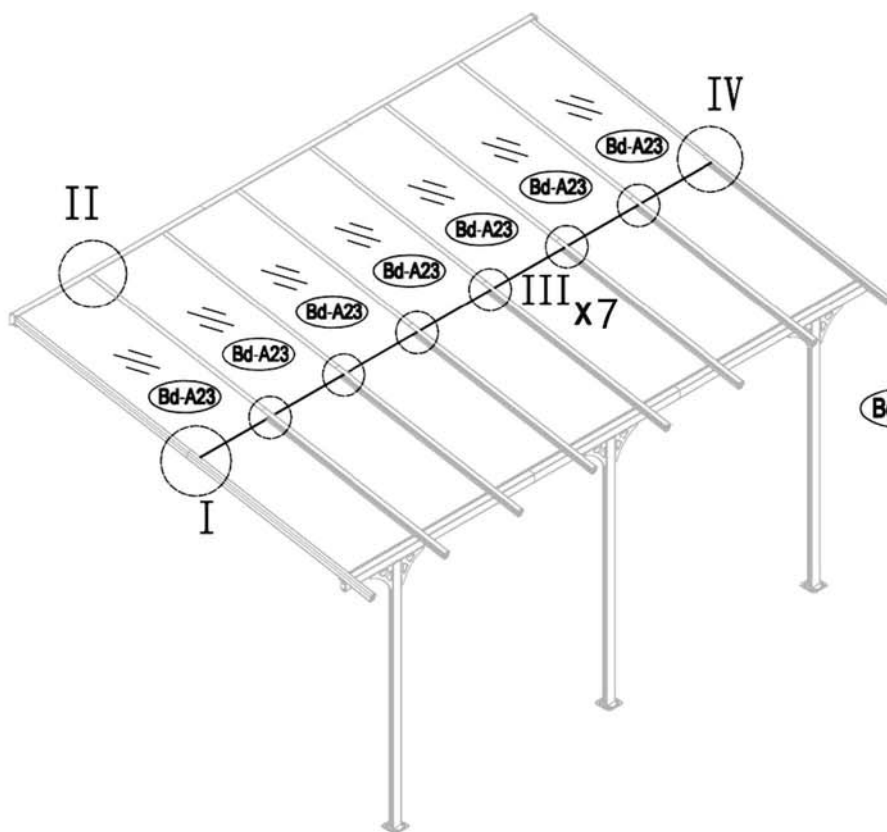

Bd-A23  x7

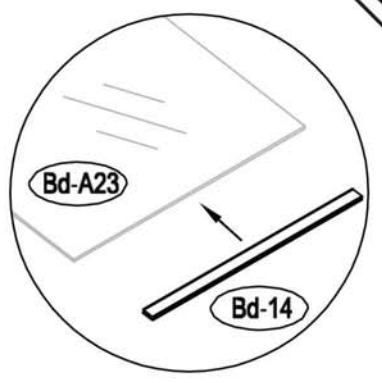
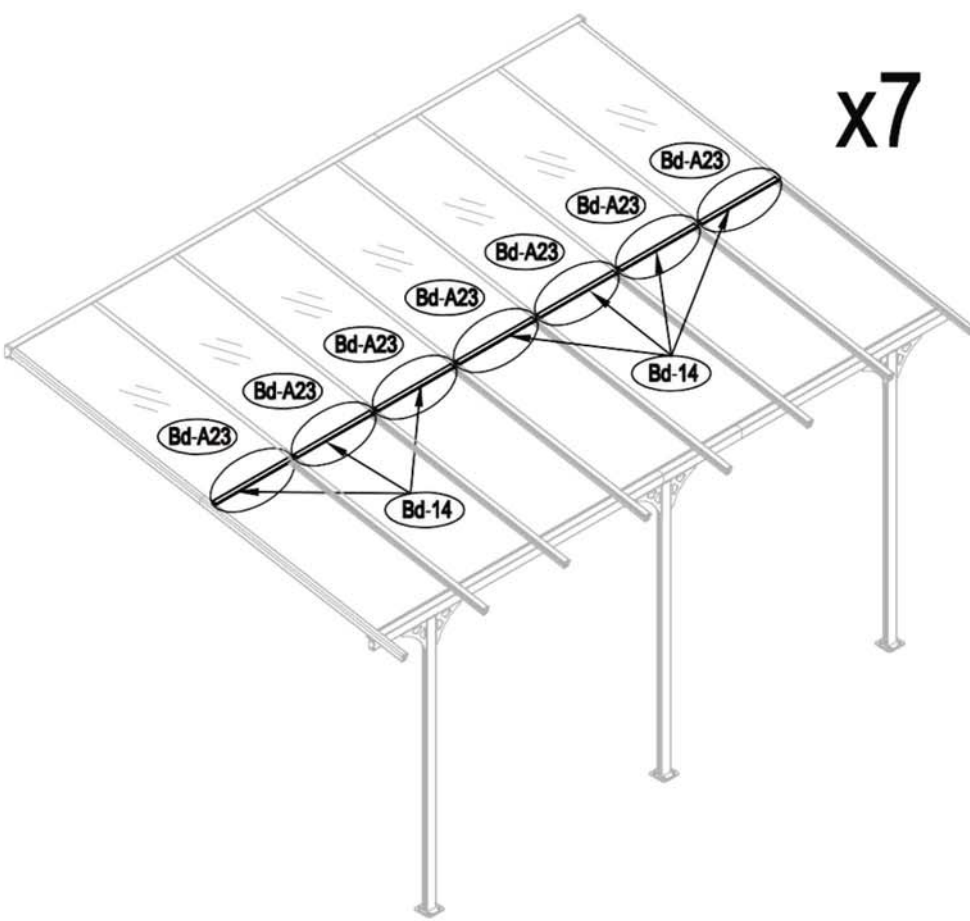



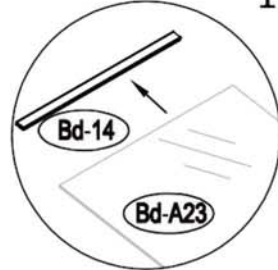
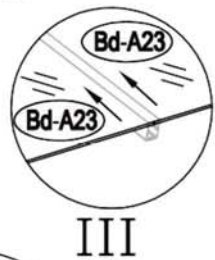
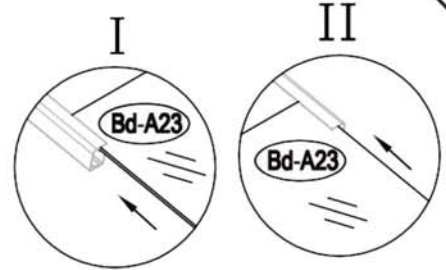
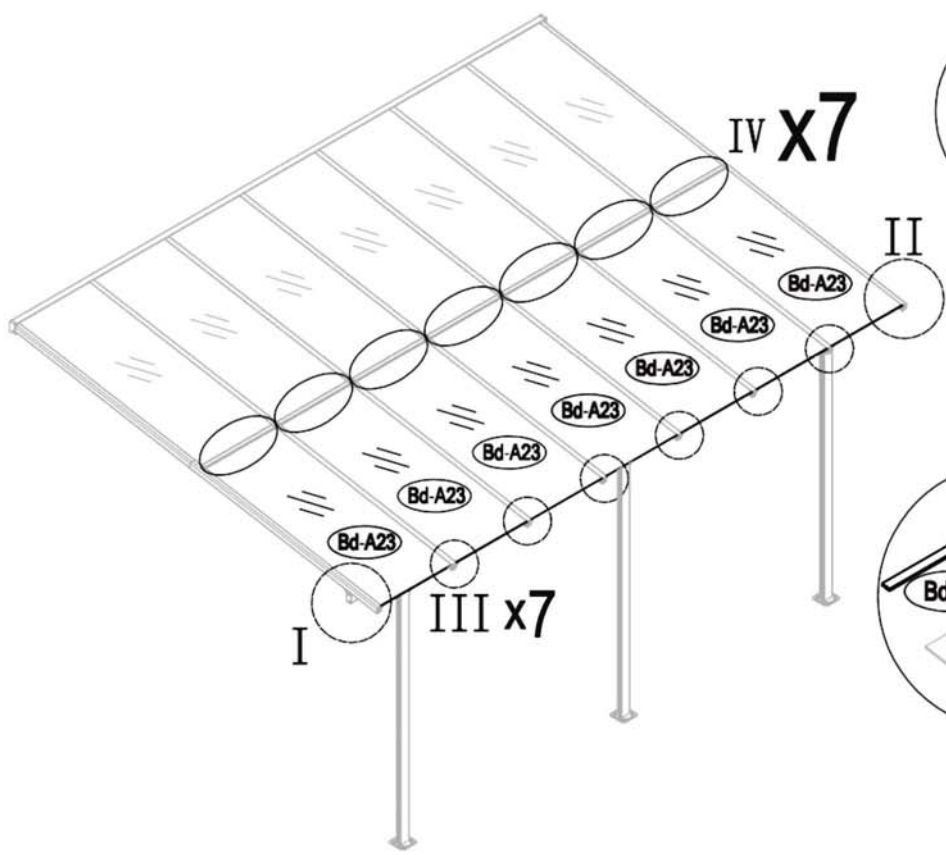

Bd-14		x7
-------	--	----

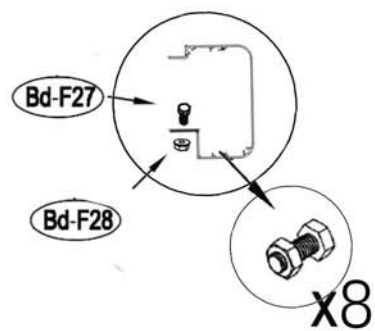
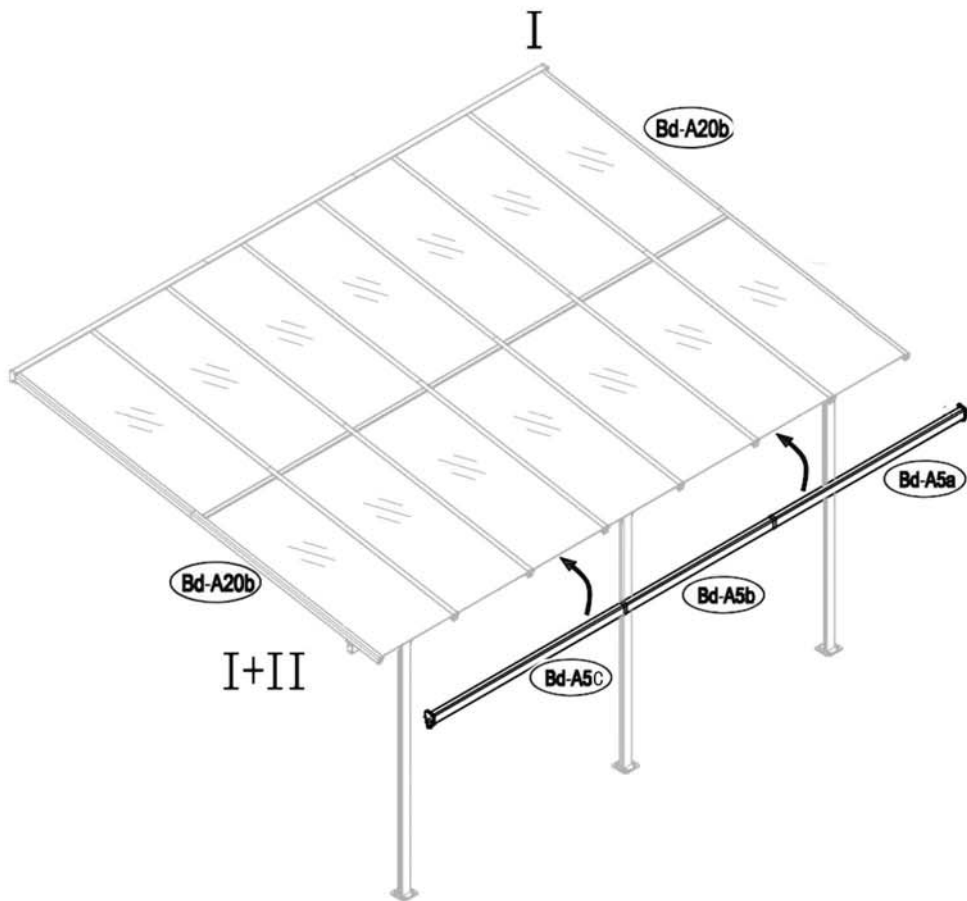

Bd-A23		x7
--------	--	----





<b>Bd-A5a</b>		1
<b>Bd-A5b</b>		1
<b>Bd-A5c</b>		1
<b>Bd-F27</b>		x8
<b>Bd-F28</b>		x8

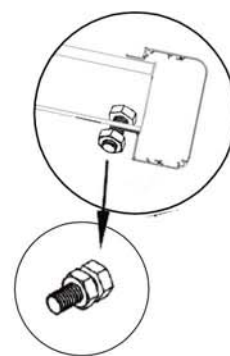
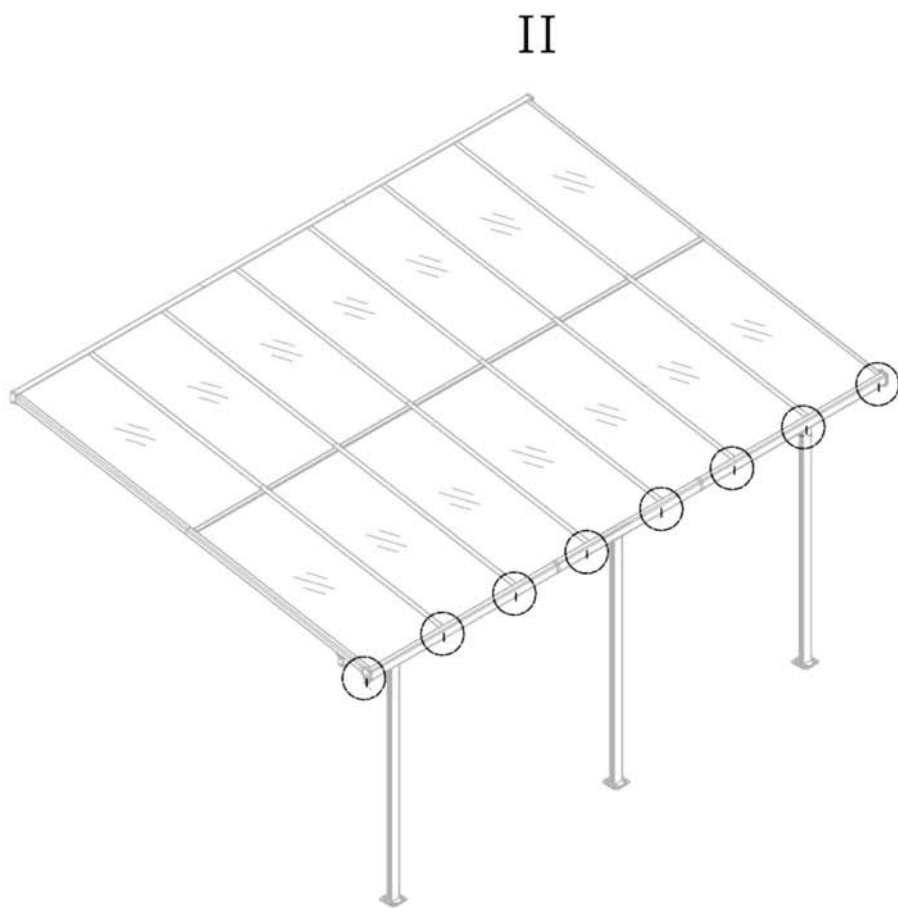



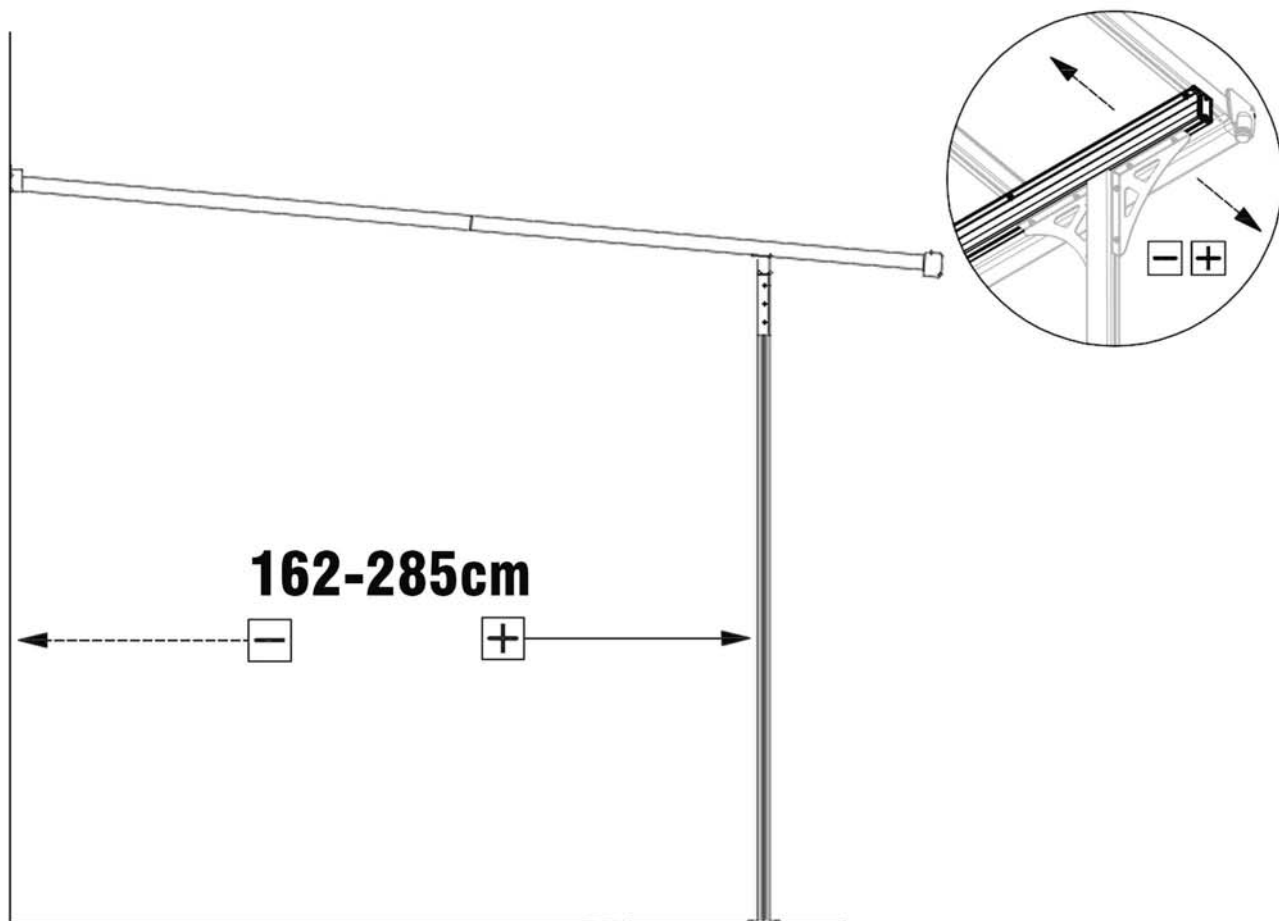
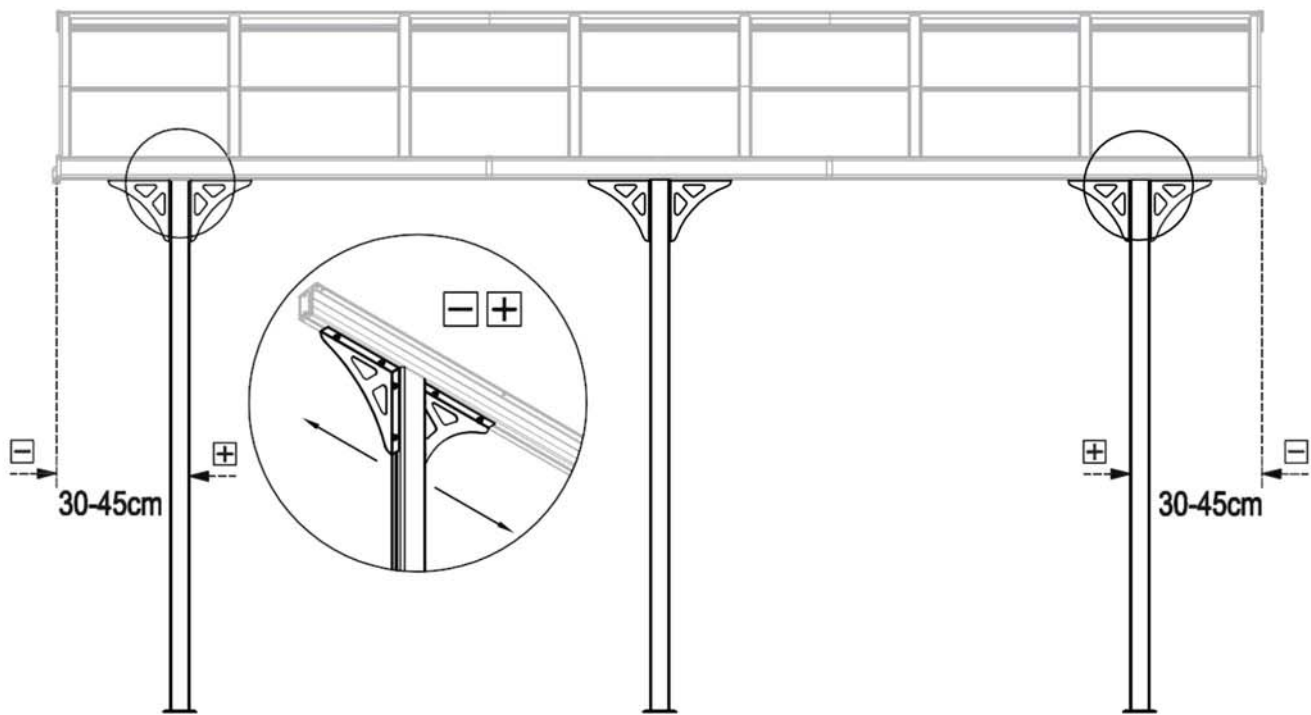

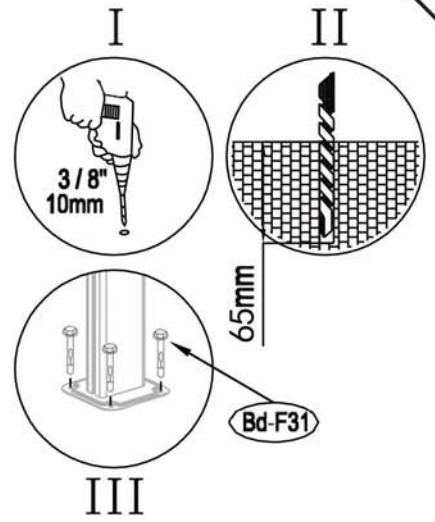
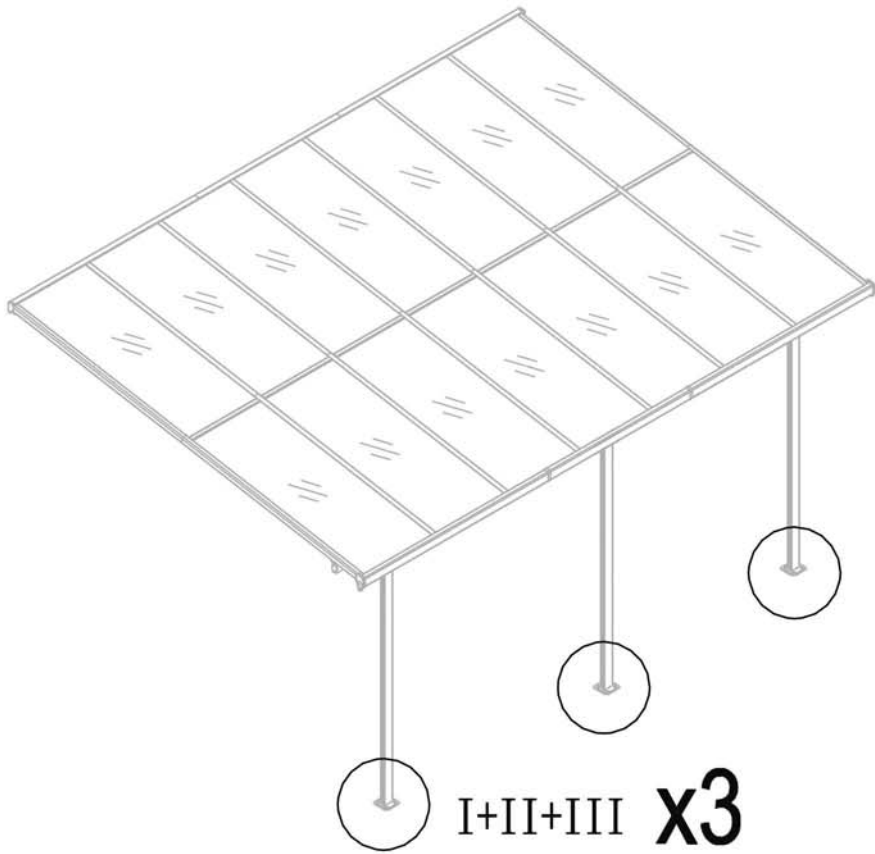

I+II+III x3

Bd-F31		x12
--------	---	-----

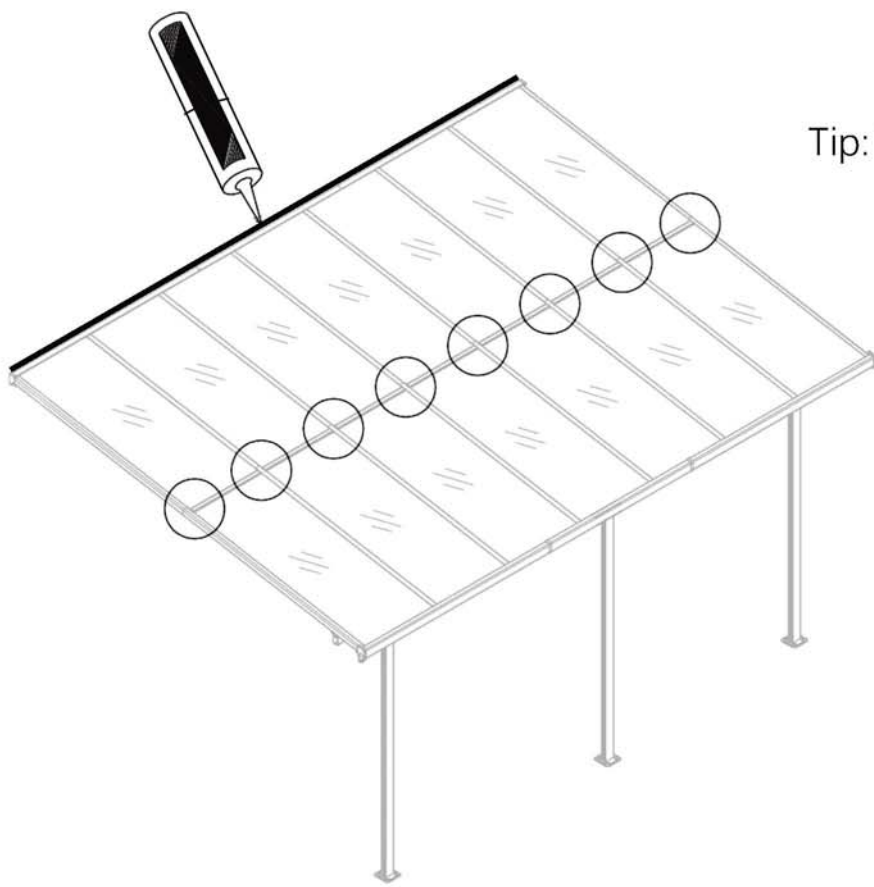

Tip: The position shown should be sealed with glue

